



EN

Cooling unit for torch cooling

Cool 55 C U40

Cool 55 C U42

099-008866-EW501

Observe additional system documents!

29.02.2024

**Register now
and benefit!
Jetzt Registrieren
und Profitieren!**

www.ewm-group.com



General instructions

WARNING



Read the operating instructions!

The operating instructions provide an introduction to the safe use of the products.

- Read and observe the operating instructions for all system components, especially the safety instructions and warning notices!
- Observe the accident prevention regulations and any regional regulations!
- The operating instructions must be kept at the location where the machine is operated.
- Safety and warning labels on the machine indicate any possible risks. Keep these labels clean and legible at all times.
- The machine has been constructed to state-of-the-art standards in line with any applicable regulations and industrial standards. Only trained personnel may operate, service and repair the machine.
- Technical changes due to further development in machine technology may lead to a differing welding behaviour.

In the event of queries on installation, commissioning, operation or special conditions at the installation site, or on usage, please contact your sales partner or our customer service department on +49 2680 181-0.

A list of authorised sales partners can be found at www.ewm-group.com/en/specialist-dealers.

Liability relating to the operation of this equipment is restricted solely to the function of the equipment. No other form of liability, regardless of type, shall be accepted. This exclusion of liability shall be deemed accepted by the user on commissioning the equipment.

The manufacturer is unable to monitor whether or not these instructions or the conditions and methods are observed during installation, operation, usage and maintenance of the equipment.

An incorrectly performed installation can result in material damage and injure persons as a result. For this reason, we do not accept any responsibility or liability for losses, damages or costs arising from incorrect installation, improper operation or incorrect usage and maintenance or any actions connected to this in any way.

© EWM GmbH

Dr. Günter-Henle-Strasse 8

56271 Mündersbach Germany

Tel.: +49 2680 181-0, Fax: -244

Email: info@ewm-group.com

www.ewm-group.com

The copyright to this document remains the property of the manufacturer.

Copying, including extracts, only permitted with written approval.

The content of this document has been prepared and reviewed with all reasonable care. The information provided is subject to change; errors excepted.

Data security

The user is responsible for backing up data of all changes from the factory setting. The user is liable for erased personal settings. The manufacturer does not assume any liability for this.

1 Contents

1 Contents	3
2 For your safety	4
2.1 Notes on using these operating instructions.....	4
2.2 Explanation of icons.....	5
2.3 Safety instructions.....	6
2.4 Transport and installation	9
3 Intended use	11
3.1 Applications.....	11
3.2 For operation only with the following equipment	11
3.3 Documents which also apply	11
3.3.1 Warranty	11
3.3.2 Declaration of Conformity.....	11
3.3.3 Service documents (spare parts and circuit diagrams).....	11
3.3.4 Part of the complete documentation.....	12
4 Machine description – quick overview	13
4.1 Front view / rear view.....	13
5 Design and function	15
5.1 Assembly/disassembly	15
5.1.1 Connecting the supply lines	15
5.2 Transport and installation	16
5.2.1 Machine cooling.....	16
5.2.2 Ambient conditions	16
5.2.3 Welding torch cooling system.....	17
5.2.3.1 Functional characteristics	17
5.2.3.2 Permitted torch coolant	17
5.2.3.3 Maximal hose package length	17
5.2.3.4 Adding coolant	18
5.2.4 Welding torch connection	19
6 Maintenance, care and disposal	20
6.1 General	20
6.2 Explanation of icons.....	20
6.3 Maintenance schedule.....	21
6.3.1 Coolant error.....	22
6.3.2 Dirt filter	23
6.3.3 Power source (inverter).....	23
6.3.4 Heat exchanger (torch cooling)	24
6.3.5 Annual test (inspection and testing during operation).....	24
6.4 Disposing of equipment	25
7 Rectifying faults	26
7.1 Checklist for rectifying faults	26
7.2 Vent coolant circuit.....	27
7.3 Fixing the pump shaft (coolant circuit).....	28
8 Technical data	29
8.1 Cool 55 C U40	29
8.2 Cool 55 C U42	30
9 Accessories	31
9.1 Welding torch cooling system	31
9.1.1 Coolant - type blueCool.....	31
9.2 Transport system	31
9.3 Option for retrofitting	31
10 Appendix	32
10.1 Searching for a dealer	32

2 For your safety

2.1 Notes on using these operating instructions

DANGER

Working or operating procedures which must be closely observed to prevent imminent serious and even fatal injuries.

- Safety notes include the "DANGER" keyword in the heading with a general warning symbol.
- The hazard is also highlighted using a symbol on the edge of the page.

WARNING

Working or operating procedures which must be closely observed to prevent serious and even fatal injuries.

- Safety notes include the "WARNING" keyword in the heading with a general warning symbol.
- The hazard is also highlighted using a symbol in the page margin.

CAUTION

Working or operating procedures which must be closely observed to prevent possible minor personal injury.

- The safety information includes the "CAUTION" keyword in its heading with a general warning symbol.
- The risk is explained using a symbol on the edge of the page.



Technical aspects which the user must observe to avoid material or equipment damage.

Instructions and lists detailing step-by-step actions for given situations can be recognised via bullet points, e.g.:

- Insert the welding current lead socket into the relevant socket and lock.

2.2 Explanation of icons

Symbol	Description	Symbol	Description
	Indicates technical aspects which the user must observe.		Activate and release / Tap / Tip
	Switch off machine		Release
	Switch on machine		Press and hold
	Incorrect / Invalid		Switch
	Correct / Valid		Turn
	Input		Numerical value – adjustable
	Navigation		Signal light lights up in green
	Output		Signal light flashes green
	Time representation (e.g.: wait 4 s / actuate)		Signal light lights up in red
	Interruption in the menu display (other setting options possible)		Signal light flashes red
	Tool not required/do not use		Signal light lights up in blue
	Tool required/use		Signal light flashes blue

2.3 Safety instructions

WARNING



Risk of accidents due to non-compliance with the safety instructions!

Non-compliance with the safety instructions can be fatal!

- Carefully read the safety instructions in this manual!
- Observe the accident prevention regulations and any regional regulations!
- Inform persons in the working area that they must comply with the regulations!



Risk of injury from electrical voltage!

Voltages can cause potentially fatal electric shocks and burns on contact. Even low voltages can cause a shock and lead to accidents.

- Never touch live components such as welding current sockets or stick, tungsten or wire electrodes!
- Always place torches and electrode holders on an insulated surface!
- Wear the full personal protective equipment (depending on the application)!
- The machine may only be opened by qualified personnel!
- The device must not be used to defrost pipes!



Hazard when interconnecting multiple power sources!

If a number of power sources are to be connected in parallel or in series, only a technical specialist may interconnect the sources as per standard IEC 60974-9:2010: Installation and use and German Accident Prevention Regulation BVG D1 (formerly VBG 15) or country-specific regulations.

Before commencing arc welding, a test must verify that the equipment cannot exceed the maximum permitted open circuit voltage.

- Only qualified personnel may connect the machine.
- When taking individual power sources out of operation, all mains and welding current leads must be safely disconnected from the welding system as a whole. (Hazard due to reverse polarity voltage!)
- Do not interconnect welding machines with pole reversing switch (PWS series) or machines for AC welding since a minor error in operation can cause the welding voltages to be combined, which is not permitted.



Risk of injury due to radiation or heat!

Arc radiation can lead to skin and eye injuries.

Contact with hot workpieces and sparks can lead to burns.

- Use hand shield or welding helmet with the appropriate safety level (depends on the application).
- Wear dry protective clothing (e.g. hand shield, gloves, etc.) in accordance with the applicable regulations of your country.
- Persons who are not directly involved should be protected with a welding curtain or suitable safety screen against radiation and the risk of blinding!

 **WARNING****Risk of injury due to improper clothing!**

During arc welding, radiation, heat and voltage are sources of risk that cannot be avoided. The user has to be equipped with the complete personal protective equipment at all times. The protective equipment has to include:

- Respiratory protection against hazardous substances and mixtures (fumes and vapours); otherwise implement suitable measures such as extraction facilities.
- Welding helmet with proper protection against ionizing radiation (IR and UV radiation) and heat.
- Dry welding clothing (shoes, gloves and body protection) to protect against warm environments with conditions comparable to ambient temperatures of 100 °C or higher and arcing and work on live components.
- Hearing protection against harming noise.

**Explosion risk!**

Apparently harmless substances in closed containers may generate excessive pressure when heated.

- Move containers with inflammable or explosive liquids away from the working area!
- Never heat explosive liquids, dusts or gases by welding or cutting!

**Fire hazard!**

Due to the high temperatures, sparks, glowing parts and hot slag that occur during welding, there is a risk of flames.

- Be watchful of potential sources of fire in the working area!
- Do not carry any easily inflammable objects, e.g. matches or lighters.
- Ensure suitable fire extinguishers are available in the working area!
- Thoroughly remove any residue of flammable materials from the workpiece prior to starting to weld.
- Only further process workpieces after they have cooled down. Do not allow them to contact any flammable materials!

⚠ CAUTION



Smoke and gases!

Smoke and gases may lead to shortness of breath and poisoning! The ultraviolet radiation of the arc may also convert solvent vapours (chlorinated hydrocarbon) into poisonous phosgene.

- Ensure sufficient fresh air!
- Keep solvent vapours away from the arc beam field!
- Wear suitable respiratory protection if necessary!
- To prevent the formation of phosgene, residues of chlorinated solvents on workpieces must first be neutralised using appropriate measures.



Noise exposure!

Noise exceeding 70 dBA can cause permanent hearing damage!

- Wear suitable ear protection!
- Persons located within the working area must wear suitable ear protection!



According to IEC 60974-10, welding machines are divided into two classes of electromagnetic compatibility (the EMC class can be found in the Technical data) > see 8 chapter:



Class A machines are not intended for use in residential areas where the power supply comes from the low-voltage public mains network. When ensuring the electromagnetic compatibility of class A machines, difficulties can arise in these areas due to interference not only in the supply lines but also in the form of radiated interference.



Class B machines fulfil the EMC requirements in industrial as well as residential areas, including residential areas connected to the low-voltage public mains network.

Setting up and operating

When operating arc welding systems, in some cases, electro-magnetic interference can occur although all of the welding machines comply with the emission limits specified in the standard. The user is responsible for any interference caused by welding.

In order to **evaluate** any possible problems with electromagnetic compatibility in the surrounding area, the user must consider the following: (see also EN 60974-10 Appendix A)

- Mains, control, signal and telecommunication lines
- Radios and televisions
- Computers and other control systems
- Safety equipment
- The health of neighbouring persons, especially if they have a pacemaker or wear a hearing aid
- Calibration and measuring equipment
- The immunity to interference of other equipment in the surrounding area
- The time of day at which the welding work must be carried out

Recommendations for reducing interference emission

- Mains connection, e.g. additional mains filter or shielding with a metal tube
- Maintenance of the arc welding system
- Welding leads should be as short as possible and run closely together along the ground
- Potential equalization
- Earthing of the workpiece. In cases where it is not possible to earth the workpiece directly, it should be connected by means of suitable capacitors.
- Shielding from other equipment in the surrounding area or the entire welding system



Electromagnetic fields!

The power source can create electrical or electromagnetic fields that may impair the function of electronic systems such as EDP and CNC devices, telecommunication, power and signal lines as well as pacemakers and defibrillators.



- Follow the maintenance instructions > see 6 chapter!
- Unwind the welding leads completely!
- Shield radiation-sensitive equipment or facilities appropriately!
- The function of pacemakers may be impaired (seek medical advice if necessary).

⚠ CAUTION**Obligations of the operator!**

The respective national directives and laws must be complied with when operating the machine!

- Implementation of national legislation relating to framework directive 89/391/EEC on the introduction of measures to encourage improvements in the safety and health of workers at work and associated individual guidelines.
- In particular, directive 89/655/EEC concerning the minimum safety and health requirements for the use of work equipment by workers at work.
- The regulations applicable to occupational safety and accident prevention in the country concerned.
- Setting up and operating the machine as per IEC 60974.-9.
- Brief the user on safety-conscious work practices on a regular basis.
- Regularly inspect the machine as per IEC 60974.-4.



The manufacturer's warranty becomes void if non-genuine parts are used!

- ***Only use system components and options (power sources, welding torches, electrode holders, remote controls, spare parts and replacement parts, etc.) from our range of products!***
- ***Only insert and lock accessory components into the relevant connection socket when the machine is switched off.***

Requirements for connection to the public mains network

High-performance machines can influence the mains quality by taking current from the mains network. For some types of machines, connection restrictions or requirements relating to the maximum possible line impedance or the necessary minimum supply capacity at the interface with the public network (Point of Common Coupling, PCC) can therefore apply. In this respect, attention is also drawn to the machines' technical data. In this case, it is the responsibility of the operator, where necessary in consultation with the mains network operator, to ensure that the machine can be connected.

2.4 Transport and installation

⚠ WARNING**Risk of injury due to improper handling of shielding gas cylinders!**

Improper handling and insufficient securing of shielding gas cylinders can cause serious injuries!

- Observe the instructions from the gas manufacturer and any relevant regulations concerning the use of compressed air!
- Do not attach any element to the shielding gas cylinder valve!
- Prevent the shielding gas cylinder from heating up.

CAUTION



Risk of accidents due to supply lines!

During transport, attached supply lines (mains leads, control cables, etc.) can cause risks, e.g. by causing connected machines to tip over and injure persons!

- Disconnect all supply lines before transport!



Risk of tipping!

There is a risk of the machine tipping over and injuring persons or being damaged itself during movement and set up. Tilt resistance is guaranteed up to an angle of 10° (according to IEC 60974-1).

- Set up and transport the machine on level, solid ground.
- Secure add-on parts using suitable equipment.



Risk of accidents due to incorrectly installed leads!

Incorrectly installed leads (mains, control and welding leads or intermediate hose packages) can present a tripping hazard.

- Lay the supply lines flat on the floor (avoid loops).
- Avoid laying the leads on passage ways.



Risk of injury from heated coolant and its connections!

The coolant used and its connection or connection points can heat up significantly during operation (water-cooled version). When opening the coolant circuit, escaping coolant may cause scalding.

- Open the coolant circuit only when the power source or cooling unit is switched off!
- Wear proper protective equipment (protective gloves)!
- Seal open connections of the hose leads with suitable plugs.



The units are designed for operation in an upright position!

Operation in non-permissible positions can cause equipment damage.

- ***Only transport and operate in an upright position!***



Accessory components and the power source itself can be damaged by incorrect connection!

- ***Only insert and lock accessory components into the relevant connection socket when the machine is switched off.***
- ***Comprehensive descriptions can be found in the operating instructions for the relevant accessory components.***
- ***Accessory components are detected automatically after the power source is switched on.***



Protective dust caps protect the connection sockets and therefore the machine against dirt and damage.

- ***The protective dust cap must be fitted if there is no accessory component being operated on that connection.***
- ***The cap must be replaced if faulty or if lost!***

3 Intended use

WARNING



Hazards due to improper usage!

The machine has been constructed to the state of the art and any regulations and standards applicable for use in industry and trade. It may only be used for the welding procedures indicated at the rating plate. Hazards may arise for persons, animals and material objects if the equipment is not used correctly. No liability is accepted for any damages arising from improper usage!

- The equipment must only be used in line with its designated purpose and by trained or expert personnel!
- Do not improperly modify or convert the equipment!

3.1 Applications

Cooling unit for cooling water-cooled welding torches.

3.2 For operation only with the following equipment

Power source	Phoenix 355 Expert 2.0 puls MM TKM Phoenix 355 Progress puls MM TKM Taurus 355 Synergic S MM TKM Taurus 355 Basic TKM
Transport vehicle	Trolley 35.2-2 Trolley 53 Trolley 54 Trolley 55-5 Trolley XQ 55-5 Trolley 55-6

3.3 Documents which also apply

3.3.1 Warranty

For more information refer to the "Warranty registration" brochure supplied and our information regarding warranty, maintenance and testing at www.ewm-group.com!

3.3.2 Declaration of Conformity



This product corresponds in its design and construction to the EU directives listed in the declaration. The product comes with a relevant declaration of conformity in the original.

The manufacturer recommends carrying out the safety inspection according to national and international standards and guidelines every 12 months (from commissioning).

3.3.3 Service documents (spare parts and circuit diagrams)

WARNING



No improper repairs and modifications!

To prevent injuries and damage to the machine, only competent personnel (authorised service personnel) are allowed to repair or modify the machine.

Unauthorised manipulations will invalidate the warranty!

- Instruct competent personnel (authorised service personnel) to repair the machine.

Original copies of the circuit diagrams are enclosed with the unit.

Spare parts can be obtained from the relevant authorised dealer.

3.3.4 Part of the complete documentation

This document is part of the complete documentation and valid only in combination with all other parts of these instructions! Read and observe the operating instructions for all system components, especially the safety instructions!

The illustration shows a general example of a welding system.

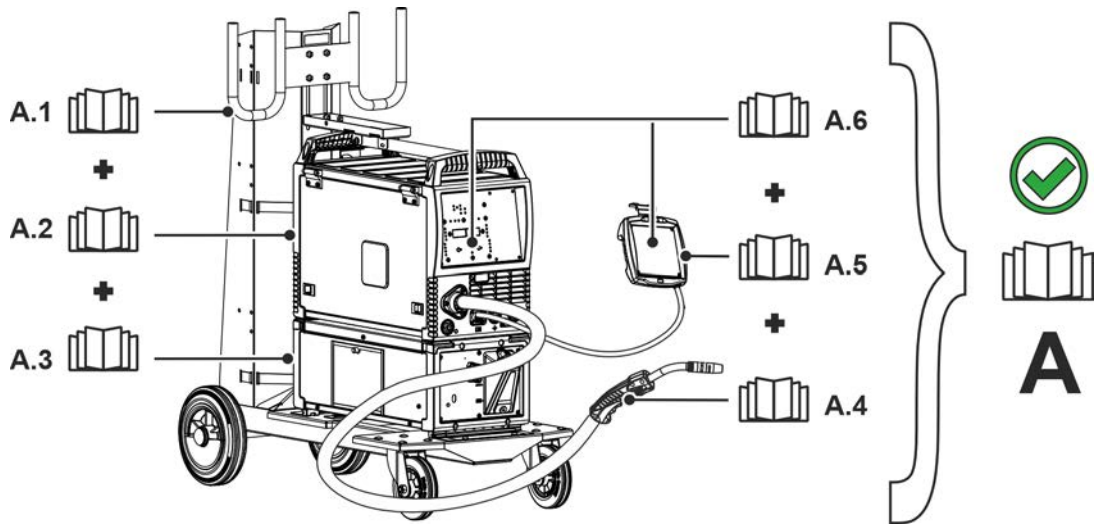

Figure 3-1

Item	Documentation
A.1	Wire feeder
A.2	Conversion instructions
A.3	Power source
A.4	Cooling unit, voltage converter, tool box etc.
A.5	Trolley
A.6	Welding torch
A.7	Remote control
A.8	Control
A	Complete documentation

4 Machine description – quick overview

4.1 Front view / rear view

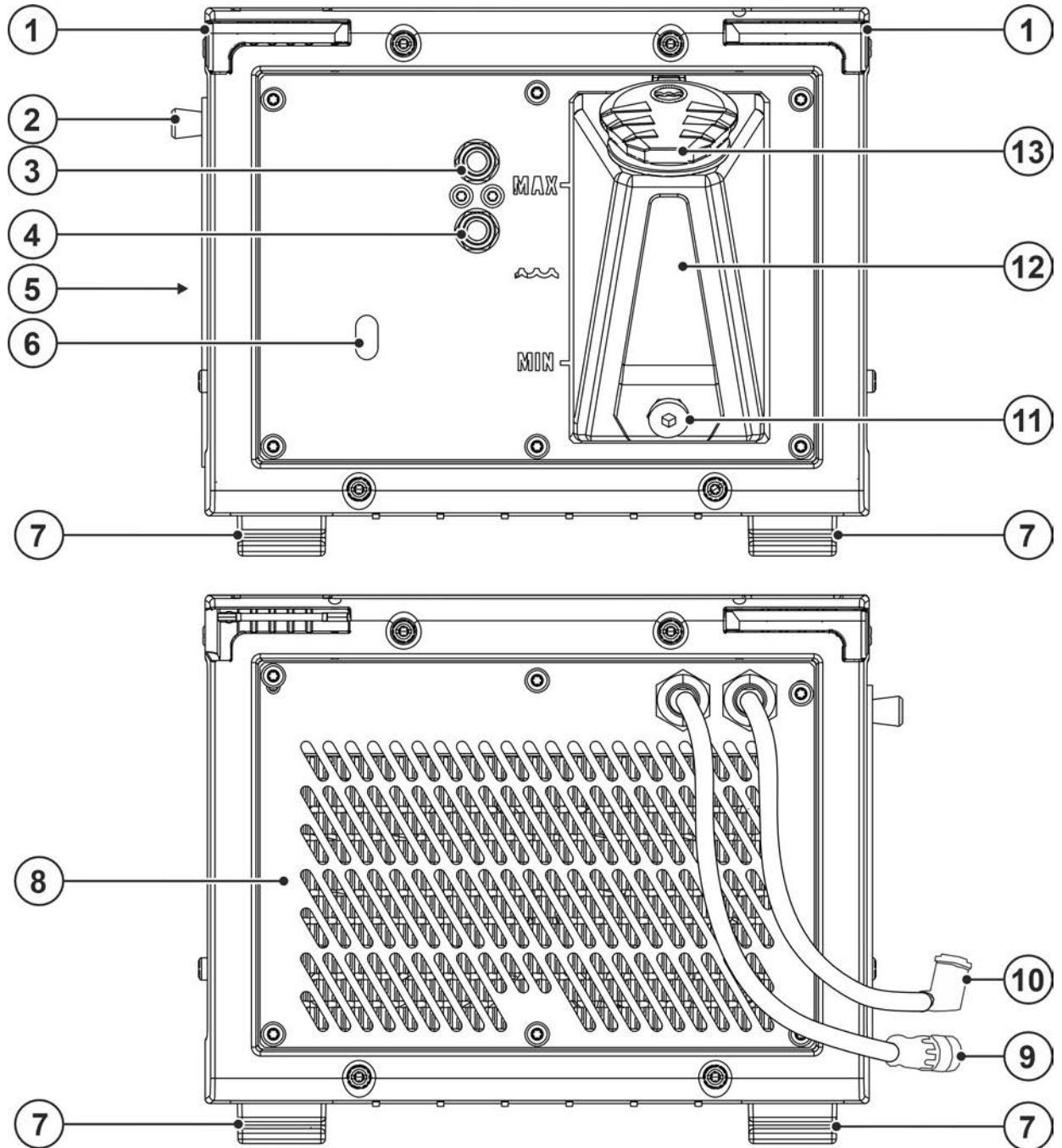



Figure 4-1

Machine description – quick overview

Front view / rear view



Item	Symbol	Description
1		Screw connector Connects cooling module and welding machine
2		Cooling air inlet Dirt filter optional > see 9.3 chapter
3		Quick connect coupling, red Coolant return from the welding torch
4		Quick connect coupling, blue Coolant supply to the welding torch
5		Cooling air inlet
6		Service opening for coolant pump > see 7.3 chapter
7		Machine feet
8		Cooling air outlet
9		Connector plug, 8-pole Cooling unit control lead
10		Connector plug, 4-pole Cooling unit voltage supply
11		Coolant drain plug > see 6.3.1 chapter
12		Coolant tank > see 5.2.3.4 chapter
13		Coolant tank cap

5 Design and function

⚠ WARNING



Risk of injury from electrical voltage!

Contact with live parts, e.g. power connections, can be fatal!

- Observe the safety information on the first pages of the operating instructions!
- Commissioning must be carried out by persons who are specifically trained in handling power sources!
- Connect connection or power cables while the machine is switched off!

Read and observe the documentation to all system and accessory components!

5.1 Assembly/disassembly

⚠ WARNING



Risk of accidents due to screw connectors that are not locked!

Attention must be paid to cleanliness and correct installation when mounting a power source with a cooling module. The cooling module could become loose if not properly mounted, thereby causing serious injuries.

- Remove dirt from the feet of the power source's unit and the screw connectors of the cooling module before mounting.
- Check that the connections are locked in place before each transport (push the screw connections back in as far as they will go)!

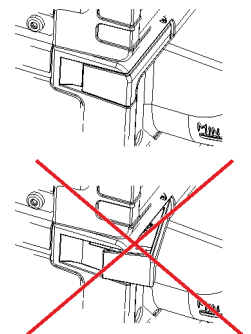

Assembly and disassembly is very simple and doesn't require any tools.

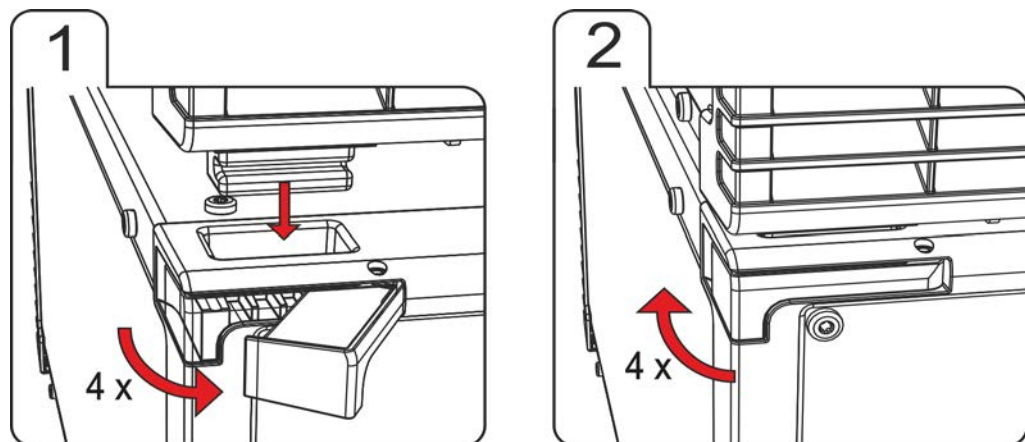

Figure 5-1

- Open out all four screw connectors on the cooling module as far as they will go.
- Position the welding machine precisely with the machine's feet in the openings of the screw connectors provided on the cooling module.
- Push all four screwed connectors back in as far as they will go.

5.1.1 Connecting the supply lines

Control and supply lead to the welding machine

The cooling module and welding machine are connected using two leads.

- Insert the control lead plug on the welding machine.
- Insert the power supply lead plug on the welding machine.

5.2 Transport and installation

WARNING



Risk of accident due to improper transport of machines that must not be lifted!
Do not lift or suspend the machine! The machine can drop and cause injuries! The handles, straps or brackets are suitable for transport by hand only!

- The machine must not be suspended or lifted using a crane.



Damage to the machine due to improper transport!

The machine can be damaged by tensile or lateral forces if it is set down or picked up in a non-vertical position!

- **Do not drag the machine horizontally on the machine feet!**
- **Always pick up the machine vertically and set it down carefully.**

5.2.1 Machine cooling



Insufficient ventilation results in a reduction in performance and equipment damage.

- **Observe the ambient conditions!**
- **Keep the cooling air inlet and outlet clear!**
- **Observe the minimum distance of 0.5 m from obstacles!**

5.2.2 Ambient conditions



The machine must not be operated in the open air and must only be set up and operated on a suitable, stable and level base!

- **The operator must ensure that the ground is non-slip and level, and provide sufficient lighting for the place of work.**
- **Safe operation of the machine must be guaranteed at all times.**



Machine damage due to contamination!

Unusually high amounts of dust, acid, corrosive gas or substances may damage the machine (note the maintenance intervals > see 6.3 chapter).

- **Prevent high amounts of smoke, weld spatter, steam, oil vapour, grinding dust and corrosive ambient air from developing!**

In operation

Temperature range of the ambient air:

- -25 °C to +40 °C (-13 °F to 104 °F) ^[1]

Relative humidity:

- up to 50 % at 40 °C (104 °F)
- up to 90 % at 20 °C (68 °F)

Transport and storage

Storage in a closed room, temperature range of the ambient air:

- -30 °C to +70 °C (-22 °F to 158 °F) ^[1]

Relative humidity

- up to 90 % at 20 °C (68 °F)

^[1] Ambient temperature dependent on coolant! Observe the coolant temperature range of the torch cooling

5.2.3 Welding torch cooling system



Material damage due to unsuitable coolants!

Unsuitable coolant, coolants mixed with other types / liquids or use in an unsuitable temperature range will result in material damage and loss of the manufacturer's warranty!

- **Operation without coolant is not permitted! Dry running will destroy the cooling components such as the coolant pump, welding torch and hose packages.**
- **Only use the coolants described in these instructions for the specified ambient conditions (temperature range) > see 5.2.3.2 chapter.**
- **Do not mix coolants of different types (including those described in these instructions).**
- **When changing the coolant, all liquid must be replaced and the cooling system flushed.**

Dispose of the coolant in accordance with local regulations and the material safety data sheets.

5.2.3.1 Functional characteristics

The cooling modules (pump and fan) are controlled by the welding machine only.

The welding machine automatically detects and displays a lack of coolant (see the welding machine operating instructions).

5.2.3.2 Permitted torch coolant

Coolant	Temperature range
blueCool -10	-10 °C to +40 °C (14 °F to +104 °F)
KF 23E	-10 °C to +40 °C (14 °F to +104 °F)
KF 37E	-20 °C to +30 °C (-4 °F to +86 °F)
blueCool -30	-30 °C to +40 °C (-22 °F to +104 °F)

5.2.3.3 Maximal hose package length

All information relates to the total hose package length of the complete welding system and presents exemplary configurations (of components of the EWM product portfolio with standard lengths). A straight kink-free installation is to be ensured, taking into account the max. delivery height.

Pump: Pmax = 3.5 bar (0.35 MPa)

Power source	Hose package	Wire feeder	miniDrive	Welding torch	max.
Compact	⊗	⊗	✓ (25 m / 82 ft.)	✓ (5 m / 16 ft.)	30 m 98 ft.
	✓ (20 m / 65 ft.)	✓	⊗	✓✓ (5 m / 16 ft.)	
Decompact	✓ (25 m / 82 ft.)	✓	⊗	✓ (5 m / 16 ft.)	
	✓ (15 m / 49 ft.)	✓	✓ (10 m / 32 ft.)	✓ (5 m / 16 ft.)	

5.2.3.4 Adding coolant

After switching on the machine, the coolant pump runs for a defined time (filling the hose package). If the machine does not detect sufficient coolant flow during this time, the coolant pump is switched off (protection against damage caused by dry running). At the same time, the welding data display signals the coolant error. If there is sufficient coolant flow, the coolant pump is switched off before the defined time has elapsed (operational readiness).

If there is less coolant in the coolant tank than the minimum required you may need to vent the coolant circuit. In this case the welding machine will automatically shut down the coolant pump and signal an error, > see 7.2 chapter.

The unit is supplied ex works with a minimum level of coolant.



The level of coolant must never fall below the "MIN" mark.

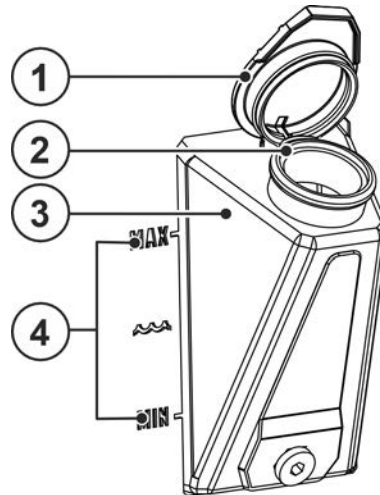

Figure 5-2

Item	Symbol	Description
1		Coolant tank cap
2		Coolant filter sieve
3		Coolant tank
4		Filling level display MIN ----- minimum coolant level MAX ----- maximum coolant level

- Pull off the coolant tank sealing cover.
- Check filter sieve for cleanliness, clean if necessary and reinsert.
- Top up coolant up to the upper filling level gauge "MAX" and push sealing cover back on.
- Switch on the power source at the main switch.

5.2.4 Welding torch connection



The cooling circuit (cooling unit <-> welding torch) must not be interrupted. Otherwise, the coolant pump can be destroyed by thermal overload (the coolant cannot circulate). When using air-cooled welding torches, one of the following measures must be taken depending on the machine version:

- Switch off the torch cooling (see function “Torch cooling mode” in the machine configuration menu of the control description).
- Insert a hose bridge between the coolant flow and return (the coolant can circulate in the cooling unit).
- Disconnect the control and supply line between the cooling unit and the welding machine.

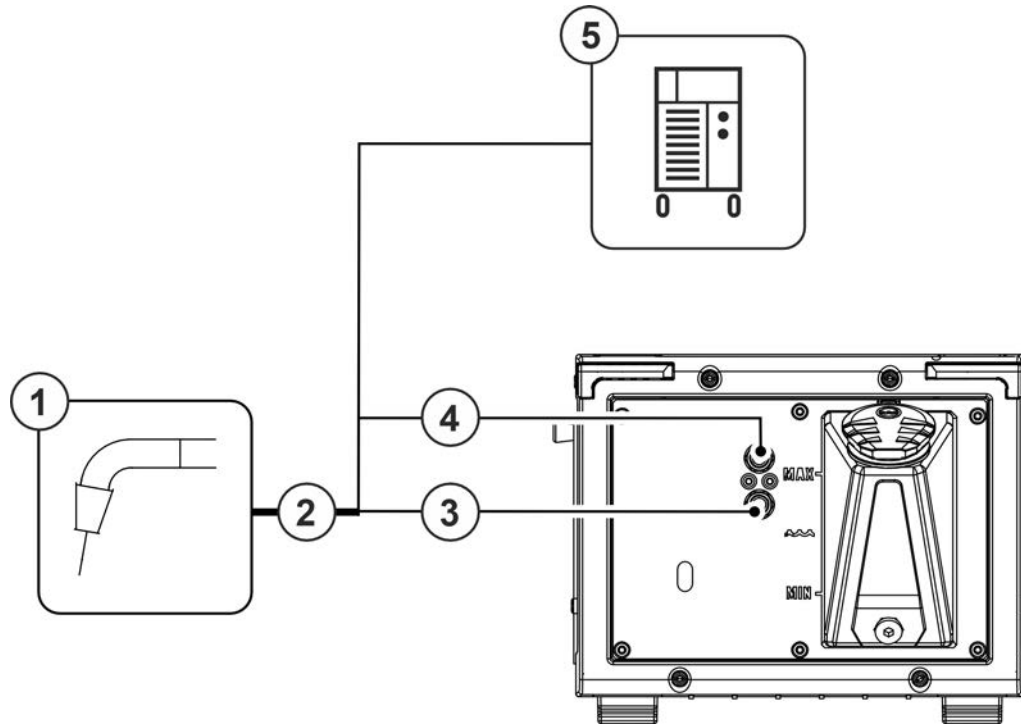

Figure 5-3

Item	Symbol	Description
1		Welding torch
2		Welding torch hose package
3		Quick connect coupling, blue Coolant supply to the welding torch
4		Quick connect coupling, red Coolant return from the welding torch
5		Power source

- Lock connecting nipples of the cooling water tubes into the corresponding quick connect couplings: Return line red to quick connect coupling, red (coolant return) and supply line blue to quick connect coupling, blue (coolant supply).

6 Maintenance, care and disposal

6.1 General

⚠ WARNING



Improper maintenance, testing and repairs!
Maintenance, testing and repair of the machine may only be carried out by skilled and qualified personnel (authorised service personnel). A competent person is someone who, based on training, knowledge and experience, can recognize the hazards and possible consequential damage that may occur when testing power sources and can take the necessary safety precautions.

- Follow the maintenance instructions > see 6.3 chapter.
- If any of the test requirements below are not met, the unit must not be put back into operation until it has been repaired and tested again.

As a rule, contact your specialised dealer, i.e. the supplier of the machine, with respect to all servicing matters. Any return deliveries in the case of warranty claims can be made via your specialised dealer only.

Only use original spare parts to replace any part. When ordering a spare part, always specify the type, serial number and article number of the machine, and the type designation and article number of the spare part.

Under the specified ambient conditions and normal working conditions this machine is essentially maintenance-free and requires just a minimum of care.

Contamination of the machine may impair service life and duty cycle. The cleaning intervals depend on the ambient conditions and the resulting contamination of the machine. The minimum interval is every six months.

6.2 Explanation of icons









Personnel

	Welder / operator		Qualified person (authorised service personnel)
---	-------------------	---	---

Test

	Visual inspection		Functional test
---	-------------------	---	-----------------

Period, interval

	One-shift operation		Multi-shift operation
	Every 8 hours		Daily
	Weekly		Monthly
	Every 6 months		Annually

6.3 Maintenance schedule

Inspector	Type of inspection	8h	24h	Maintenance step	Repairer
				<p>! Only personnel designated as inspectors or repairers due to their training are allowed to carry out the relevant work step! Inapplicable checkpoints are omitted.</p>	
				<ul style="list-style-type: none"> Check and clean the welding torch. Deposits in the welding torch may cause short circuits, impair the welding result and lead to welding torch damage! Connections of the welding current leads (check for tight and locked seating). Is shielding gas cylinder with gas cylinder securing elements (chain/belt) secured? Strain relief: Are hose packages secured with strain relief? 	
				<ul style="list-style-type: none"> Checking all supply lines and their connections (pipes, hoses, hose packages) for damage or leaks. Checking the welding system for damage to the housing. Transport elements (strap, lifting eyes, handle, wheels, parking brake) corresponding safety elements (if necessary fuse caps) are present and flawless? 	
				<ul style="list-style-type: none"> Cleaning connections of coolant pipes (quick connect coupling, connections) from impurities and install protective caps when not in use. Gas test that the solenoid valve opens and closes properly. Checking operating, signalling and indicator lights, protective devices and actuators. 	
				<ul style="list-style-type: none"> Cleaning dirt filter (if applicable) 	
				<ul style="list-style-type: none"> Clean external surfaces with a damp cloth (do not use aggressive cleaning agents). 	
				<ul style="list-style-type: none"> Cleaning the power source (inverter) 	
				<ul style="list-style-type: none"> Cleaning heat exchanger (torch cooling) 	
				<ul style="list-style-type: none"> Coolant change (torch cooling) 	
				<ul style="list-style-type: none"> Periodic inspection and testing 	
				<ul style="list-style-type: none"> The coolant must be checked using the appropriate frost protection tester TYP 1 (KF) or FSP (blueCool) for sufficient frost protection and replaced if necessary (accessories). 	

6.3.1 Coolant error

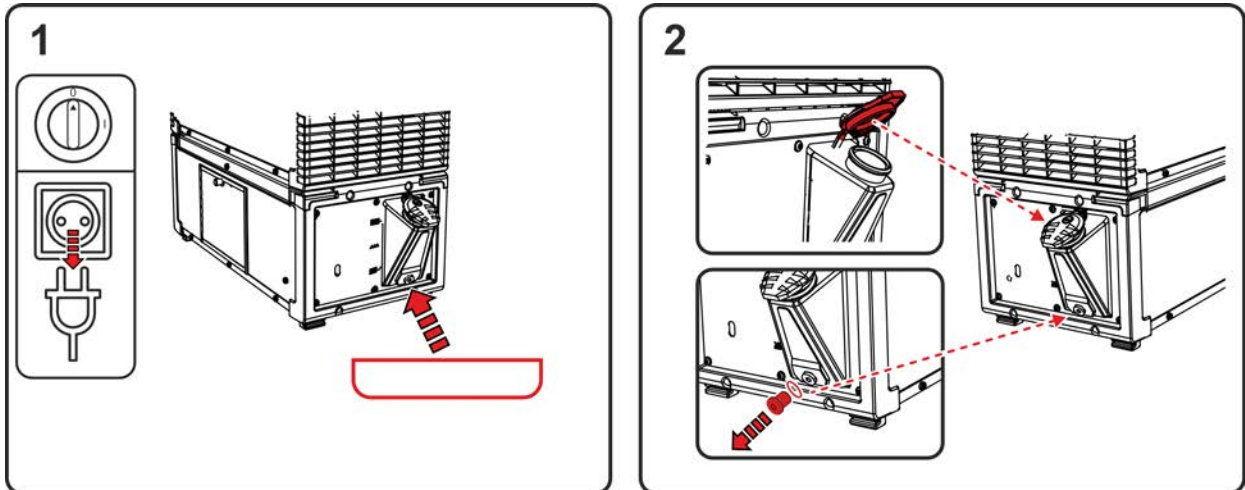

Figure 6-1

- Switch off the machine and disconnect the mains plug. Position a suitable collecting container under the drain plug of the coolant tank.
- Unscrew the drain plug of the coolant tank (remove the tank cap to ventilate).

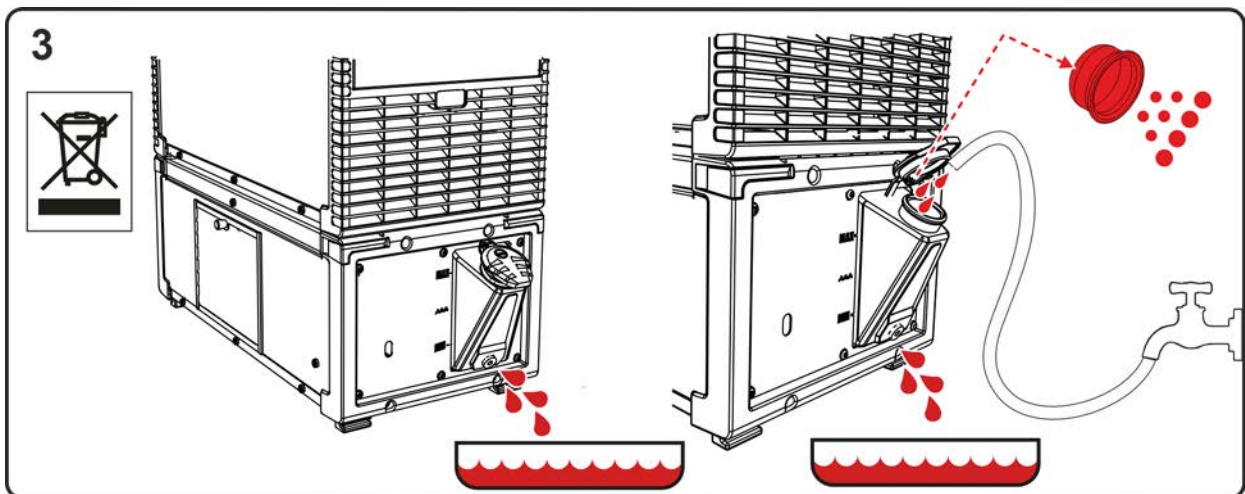

Figure 6-2

- Wait until the coolant has run out of the tank into the collection container.
- Remove the filter screen from the filler neck and clean.
- Then rinse the dirt out of the tank with water.

Follow official regulations on disposal!

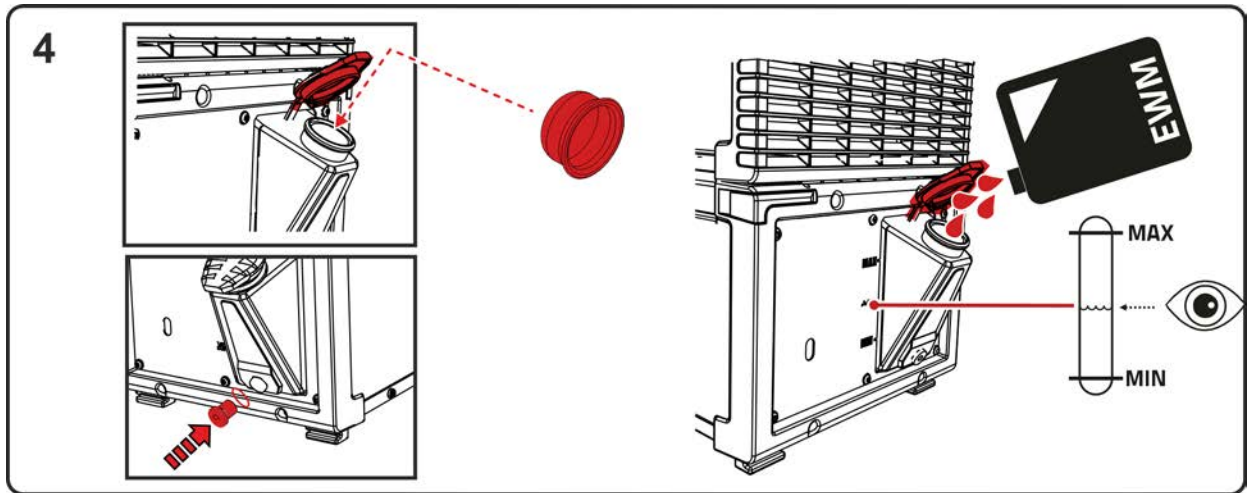

Figure 6-3

- Insert the cleaned filter screen into the filler neck and screw the drain plug with seal back into the tank.
- Fill the tank with original EWM coolant up to the maximum level. After filling, refit the tank cap and vent the coolant circuit > see 7.2 chapter.

6.3.2 Dirt filter

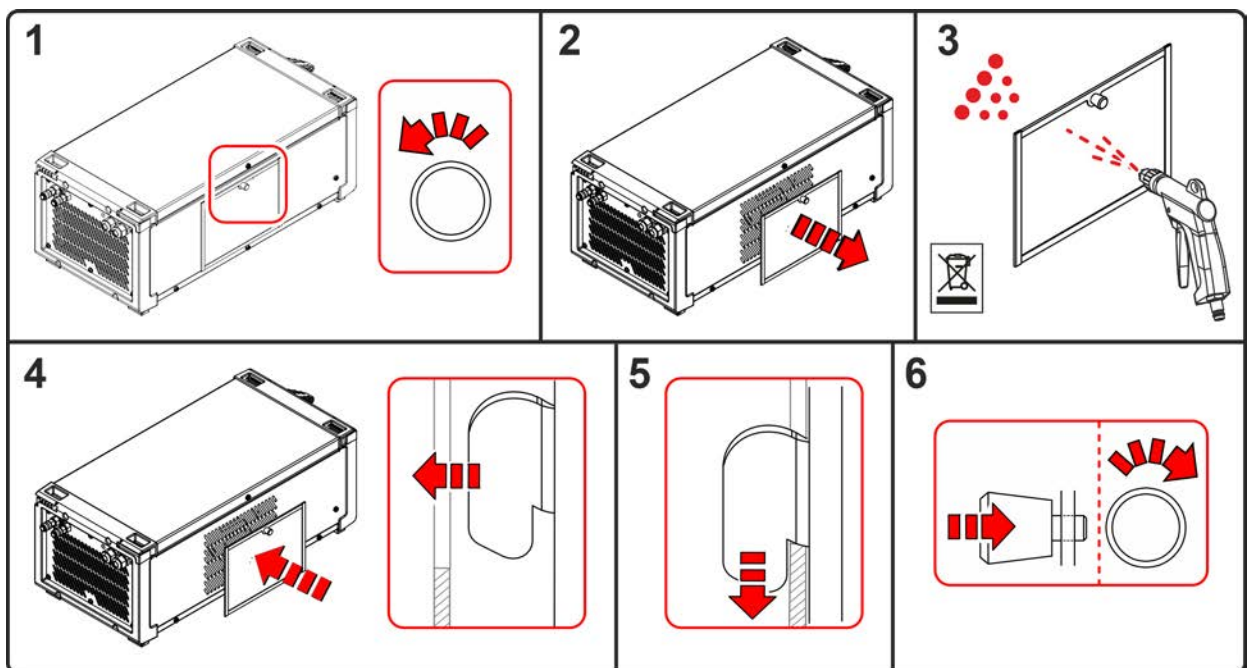

Figure 6-4

- Remove the dirt filter and blow out with compressed air free of oil and water.
- After cleaning, reassemble in reverse order.

Follow the official regulations for the disposal of dirt residues!

6.3.3 Power source (inverter)

WARNING



Risk of injury due to insufficient training!

Appropriate training is required for the following maintenance steps to prevent injuries.

- Only authorised service personnel may carry out this maintenance step.
- Note the warnings and maintenance instructions at the beginning of this chapter!

Detailed descriptions of how to clean the power source (inverter) can be found in the relevant service instructions.

6.3.4 Heat exchanger (torch cooling)

WARNING



Risk of injury due to insufficient training!

Appropriate training is required for the following maintenance steps to prevent injuries.

- Only authorised service personnel may carry out this maintenance step.
- Note the warnings and maintenance instructions at the beginning of this chapter!

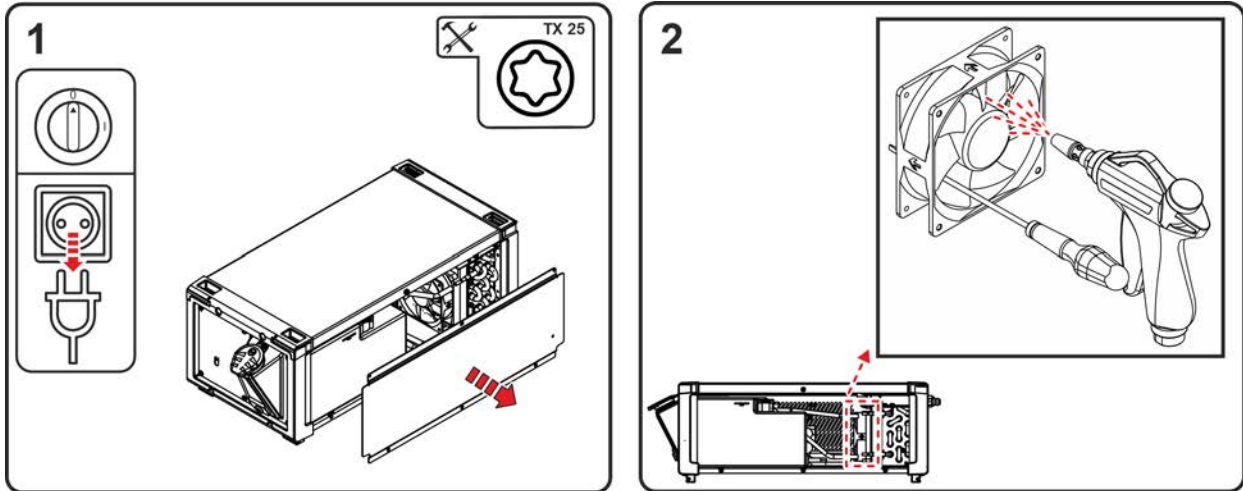

Figure 6-5

- Switch off the machine and disconnect the mains plug. Remove the screws of the side panels. Remove side panels (fold out sideways at the bottom and pull out downwards).
- Clean the machine fan with compressed air free of oil and water.



Block the fan wheel of the machine fan mechanically (the machine fan may over-rotate due to the compressed air and be damaged as a result)!

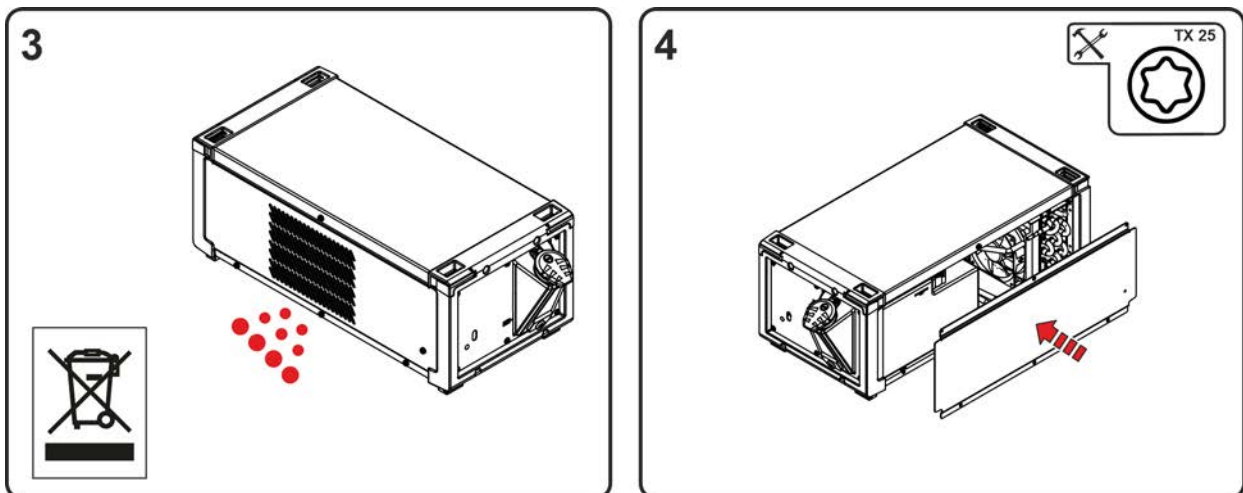

Figure 6-6

Follow official regulations on disposal!

- After cleaning, remove any mechanical blockages from the fans, close the machine in reverse order and check according to applicable regulations.

6.3.5 Annual test (inspection and testing during operation)

A periodic test according to IEC 60974-4 "Periodic inspection and test" has to be carried out. In addition to the regulations on testing given here, the relevant local laws and regulations must also be observed.

For more information refer to the "Warranty registration" brochure supplied and our information regarding warranty, maintenance and testing at www.ewm-group.com!

6.4 Disposing of equipment



Proper disposal!

The machine contains valuable raw materials, which should be recycled, and electronic components, which must be disposed of.

- Do not dispose of in household waste!
- Observe the local regulations regarding disposal!

In addition to the national or international regulations mentioned below, it is mandatory to follow the respective national laws and regulations on disposal.

- According to European provisions (Directive 2012/19/EU on Waste of Electrical and Electronic Equipment), used electric and electronic equipment may no longer be placed in unsorted municipal waste. It must be collected separately. The symbol depicting a waste container on wheels indicates that the equipment must be collected separately.

This machine has to be disposed of, or recycled, in accordance with the waste separation systems in use.

According to German law (law governing the distribution, taking back and environmentally correct disposal of electrical and electronic equipment (ElektroG)), used machines are to be placed in a collection system separate from unsorted municipal waste. The public waste management utilities (communities) have created collection points at which used equipment from private households can be disposed of free of charge.

The deletion of personal data is the responsibility of the end user.

Lamps, batteries or accumulators must be removed and disposed of separately before disposing of the device. The type of battery or accumulator and its composition is marked on the top (type CR2032 or SR44). The following EWM products may contain batteries or accumulators:

- Welding helmets
Batteries or accumulators are easy to remove from the LED cassette.
- Device controls
Batteries or accumulators are located on the back of these in corresponding sockets on the circuit board and are easy to remove. The controls can be removed using standard tools.

Information on returning used equipment or collections can be obtained from the respective municipal administration office. Devices can also be returned to EWM sales partners across Europe.

Further information on the topic of the disposal of electrical and electronic equipment can be found on our website at: <https://www.ewm-group.com/de/nachhaltigkeit.html>.

7 Rectifying faults

All products are subject to rigorous production checks and final checks. If, despite this, something fails to work at any time, please check the product using the following flowchart. If none of the fault rectification procedures described leads to the correct functioning of the product, please inform your authorised dealer.

7.1 Checklist for rectifying faults

The correct machine equipment for the material and process gas in use is a fundamental requirement for perfect operation!

Please observe the welding machine operating instructions.

Legend	Symbol	Description
	↘	Fault/Cause
	✘	Remedy

Coolant error/no coolant flowing

- ↘ Insufficient coolant flow
 - ✘ Check coolant level and refill if necessary
 - ✘ Eliminate kinks in conduit system (hose packages)
 - ✘ Extend and lay out the torch hose package
 - ✘ Reset automatic cutout of the coolant pump by activating
- ↘ Air in the coolant circuit
 - ✘ Vent coolant circuit > see 7.2 chapter
- ↘ Coolant pump blocked
 - ✘ Switch on pump shaft (specialist staff only) > see 7.3 chapter

Functional errors

- ↘ Connection problems
 - ✘ Make control lead connections and check that they are fitted correctly.

7.2 Vent coolant circuit

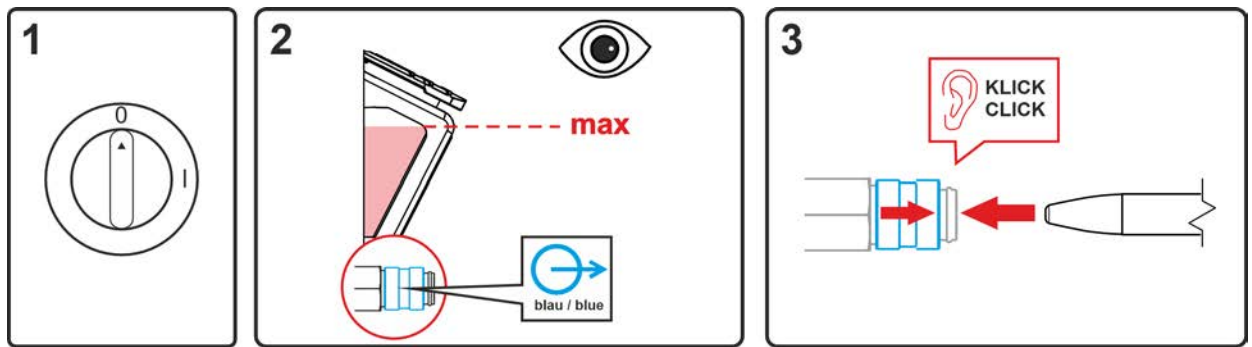

Figure 7-1

- Switch off the machine and fill the coolant tank to the maximum level.
- Unlock the quick-connect coupling with a suitable tool (connection open).

To vent the cooling system always use the blue coolant connection, which is located as deep as possible inside the system (close to the coolant tank)!

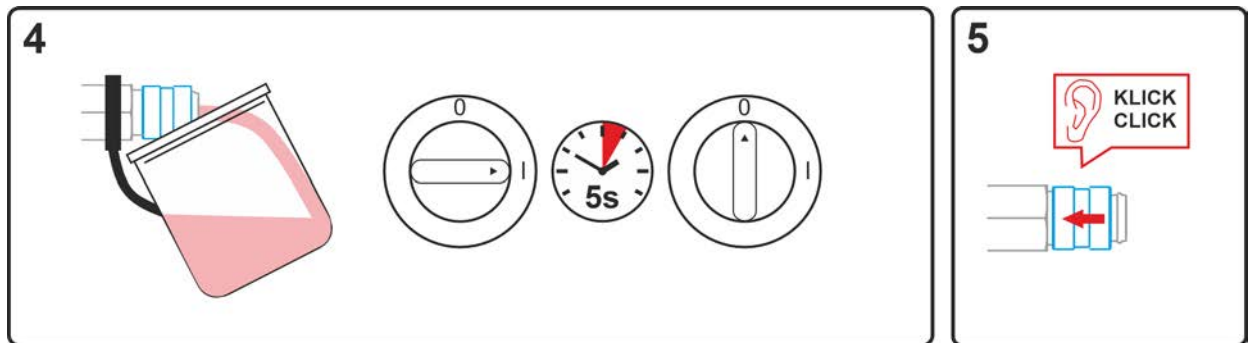

Figure 7-2

- Position a suitable collection container for collecting the escaping coolant at the quick-connect coupling and switch on the machine for approx. 5s.
- Lock the quick-connect coupling by pushing back the locking ring.

7.3 Fixing the pump shaft (coolant circuit)

WARNING



No improper repairs and modifications!

To prevent injuries and damage to the machine, only competent personnel (authorised service personnel) are allowed to repair or modify the machine.

Unauthorised manipulations will invalidate the warranty!

- Instruct competent personnel (authorised service personnel) to repair the machine.



Risk of injury from electrical voltage!

Voltages can cause potentially fatal electric shocks and burns on contact. Even low voltages can cause a shock and lead to accidents.

- Never touch live components such as welding current sockets or stick, tungsten or wire electrodes!
- Always place torches and electrode holders on an insulated surface!
- Wear the full personal protective equipment (depending on the application)!
- The machine may only be opened by qualified personnel!
- The device must not be used to defrost pipes!

Continuing non-use and impurities in the coolant may result in the the coolant pump not being in proper working order.

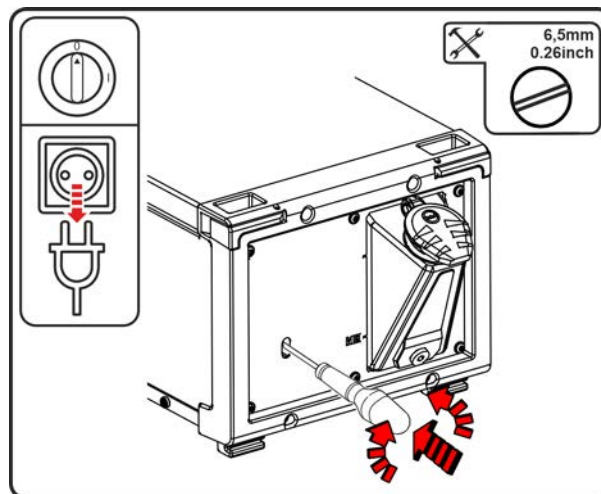

Figure 7-3

- Switch off machine at the main switch.
- Insert a plain slot screwdriver with a maximum tip width of 6.5 mm through the maintenance opening and place in the centre of the pump shaft. Turn the screwdriver clockwise until the pump shaft can be easily rotated again.
- Remove screwdriver.
- Switch on the power source at the main switch.

8 Technical data

The limit value determination of technical data results from considering the combined overall system (cooling unit and welding machine).

8.1 Cool 55 C U40

Supply voltage (from the welding machine)	400 V
Frequency	50/60 Hz
Cooling capacity at 1 l/min (+25°C/77°F) ^[1]	1200 W
Ambient temperature	-25 °C to +40 °C
max. Flow rate	5 l/min 1,3 gal/min
max. Delivery height	35 m 115 ft
max. Pump pressure	3,5 bar 0.35 MPa
Pump	Centrifugal pump
max. Tank content	4,5 l 1.2 gal
Protection class	I
Overvoltage category	III
Contamination level	3
Coolant	> see 5.2.3.2 chapter
Machine cooling / protection classification	Fan (AF) / IP 23 ^[2]
Noise level ^[3]	< 70 dB(A)
EMC class	A
Test mark	CE / ENEC / UKCA
Standards used	See declaration of conformity (appliance documents)
Dimensions (l x b x h)	665 x 298 x 247 mm 26.2 x 11.7 x 9.7 inch
without coolant	19 kg 41.9 lb

^[1] Ambient temperature dependent on coolant! Observe coolant temperature range!

^[2] Mounted state

^[3] Noise level during idle mode and operation under standard load according to IEC 60974- 1 at the maximum operating point.

8.2 Cool 55 C U42

Supply voltage (from the welding machine)	400 V
Frequency	50/60 Hz
Cooling capacity at 1 l/min (+25°C/77°F) ^[1]	1200 W
Ambient temperature	-25 °C to +40 °C
max. Flow rate	20 l/min 5,3 gal/min
max. Delivery height	45 m 148 ft
max. Pump pressure	4,5 bar 0.45 MPa
Pump	Centrifugal pump
max. Tank content	4,5 l 1.2 gal
Protection class	I
Overvoltage category	III
Contamination level	3
Coolant	> see 5.2.3.2 chapter
Machine cooling / protection classification	Fan (AF) / IP 23 ^[2]
Noise level ^[3]	< 70 dB(A)
EMC class	A
Test mark	CE / ENEC / UKCA
Standards used	See declaration of conformity (appliance documents)
Dimensions (l x b x h)	665 x 298 x 247 mm 26.2 x 11.7 x 9.7 inch
without coolant	21,5 kg 47.4 lb

^[1] Ambient temperature dependent on coolant! Observe coolant temperature range!

^[2] Mounted state

^[3] Noise level during idle mode and operation under standard load according to IEC 60974- 1 at the maximum operating point.

9 Accessories

9.1 Welding torch cooling system

Type	Designation	Item no.
HOSE BRIDGE UNI	Tube bridge	092-007843-00000
LFMG HANNA DIST 3	Conductivity meter	094-026184-00000

9.1.1 Coolant - type blueCool

Type	Designation	Item no.
blueCool -10 5 l	Coolant up to -10 °C (14 °F), 5 l	094-024141-00005
blueCool -10 25 l	Coolant up to -10 °C (14 °F), 25 l	094-024141-00025
blueCool -30 5 l	Coolant up to -30 °C (22 °F), 5 l	094-024142-00005
blueCool -30 25 l	Coolant up to -30 °C (22 °F), 25 l	094-024142-00025
FSP blueCool	Frost protection tester	094-026477-00000

9.2 Transport system

Type	Designation	Item no.
Trolley 35.2-2	Transport vehicle	090-008296-00000
Trolley 53	Transport cart	090-008638-00000
Trolley 54	Transport vehicle	090-008639-00000
Type	Designation	Item no.
Trolley 55-5	Transport cart, assembled	090-008632-00000
Trolley 55-5 TM	Transport cart (4 castors) for transporting a power source, a cooling unit or a tool box and a shielding gas cylinder, partially assembled	090-008632-00001
ON TR Trolley 55-5 / 55-6	Cross arm and holder for wire feeder	092-002700-00000
Type	Designation	Item no.
Trolley XQ 55-5	Transport cart, assembled	090-008636-00000
ON TR Trolley 55-5 / 55-6	Cross arm and holder for wire feeder	092-002700-00000
Type	Designation	Item no.
Trolley 55-6	Transport cart, assembled	090-008825-00000
ON TR Trolley 55-5 / 55-6	Cross arm and holder for wire feeder	092-002700-00000

9.3 Option for retrofitting

Type	Designation	Item no.
ON Filter K.07	Dirt filter for the air inlet	092-004630-00000

10 Appendix

10.1 Searching for a dealer

Sales & service partners
www.ewm-group.com/en/specialist-dealers



"More than 400 EWM sales partners worldwide"