

Wire feed unit

Drive 4X S

099-005719-EW501

Observe additional system documents!

09.04.2024

**Register now  
and benefit!**  
**Jetzt Registrieren  
und Profitieren!**

[www.ewm-group.com](http://www.ewm-group.com)



# General instructions

## WARNING



### **Read the operating instructions!**

**The operating instructions provide an introduction to the safe use of the products.**

- Read and observe the operating instructions for all system components, especially the safety instructions and warning notices!
- Observe the accident prevention regulations and any regional regulations!
- The operating instructions must be kept at the location where the machine is operated.
- Safety and warning labels on the machine indicate any possible risks. Keep these labels clean and legible at all times.
- The machine has been constructed to state-of-the-art standards in line with any applicable regulations and industrial standards. Only trained personnel may operate, service and repair the machine.
- Technical changes due to further development in machine technology may lead to a differing welding behaviour.

**In the event of queries on installation, commissioning, operation or special conditions at the installation site, or on usage, please contact your sales partner or our customer service department on +49 2680 181-0.**

**A list of authorised sales partners can be found at [www.ewm-group.com/en/specialist-dealers](http://www.ewm-group.com/en/specialist-dealers).**

Liability relating to the operation of this equipment is restricted solely to the function of the equipment. No other form of liability, regardless of type, shall be accepted. This exclusion of liability shall be deemed accepted by the user on commissioning the equipment.

The manufacturer is unable to monitor whether or not these instructions or the conditions and methods are observed during installation, operation, usage and maintenance of the equipment.

An incorrectly performed installation can result in material damage and injure persons as a result. For this reason, we do not accept any responsibility or liability for losses, damages or costs arising from incorrect installation, improper operation or incorrect usage and maintenance or any actions connected to this in any way.

### © EWM GmbH

Dr. Günter-Henle-Strasse 8  
56271 Mündersbach Germany  
Tel.: +49 2680 181-0, Fax: -244  
Email: [info@ewm-group.com](mailto:info@ewm-group.com)

**[www.ewm-group.com](http://www.ewm-group.com)**

The copyright to this document remains the property of the manufacturer.

Copying, including extracts, only permitted with written approval.

The content of this document has been prepared and reviewed with all reasonable care. The information provided is subject to change; errors excepted.

### **Data security**

The user is responsible for backing up data of all changes from the factory setting. The user is liable for erased personal settings. The manufacturer does not assume any liability for this.

# 1 Contents

<b>1</b>	<b>Contents.....</b>	<b>3</b>
<b>2</b>	<b>For your safety.....</b>	<b>5</b>
2.1	Notes on using these operating instructions .....	5
2.2	Explanation of icons .....	6
2.3	Safety instructions.....	7
2.4	Transport and installation .....	10
<b>3</b>	<b>Intended use.....</b>	<b>12</b>
3.1	Applications.....	12
3.2	Use and operation solely with the following machines .....	12
3.3	Documents which also apply.....	12
3.3.1	Warranty.....	12
3.3.2	Declaration of Conformity.....	12
3.3.3	Service documents (spare parts and circuit diagrams).....	12
3.3.4	Calibration/Validation .....	12
3.3.5	Part of the complete documentation.....	13
<b>4</b>	<b>Machine description – quick overview.....</b>	<b>14</b>
4.1	Front view / side view from the right.....	14
4.2	Rear view / side view from left.....	16
<b>5</b>	<b>Design and function.....</b>	<b>18</b>
5.1	Transport and installation .....	18
5.1.1	Ambient conditions .....	18
5.1.2	Workpiece lead, general.....	19
5.1.3	Welding torch cooling system .....	19
5.1.3.1	Permitted torch coolant .....	19
5.1.3.2	Maximal hose package length .....	20
5.1.4	Notes on the installation of welding current leads.....	21
5.1.5	Stray welding currents.....	22
5.2	Intermediate hose package connection.....	23
5.2.1	Intermediate hose package strain relief.....	24
5.2.1.1	Locking the strain relief .....	24
5.2.2	Shielding gas supply (shielding gas cylinder for welding machine).....	24
5.2.2.1	Pressure regulator connection.....	24
5.2.2.2	Gas test – setting the shielding gas volume.....	25
5.2.2.3	Setting the shielding gas volume (gas test)/rinse hose package.....	25
5.2.3	Protective flap, welding machine control.....	26
5.3	MIG/MAG welding.....	26
5.3.1	Assemble the wire guide.....	26
5.3.2	Welding torch connection.....	28
5.3.3	Wire feed.....	29
5.3.3.1	Inserting the wire spool .....	29
5.3.3.2	Changing the wire feed rollers .....	30
5.3.3.3	Inching the wire electrode .....	33
5.3.3.4	Spool brake setting.....	34
5.3.4	Standard MIG/MAG torch.....	34
5.3.5	Welding task selection.....	34
5.4	TIG welding.....	35
5.4.1	Welding torch connection.....	35
5.4.2	Welding task selection.....	35
<b>6</b>	<b>Maintenance, care and disposal.....</b>	<b>36</b>
6.1	General.....	36
6.2	Explanation of icons .....	36
6.3	Maintenance schedule.....	37
6.4	Disposing of equipment.....	38
<b>7</b>	<b>Rectifying faults.....</b>	<b>39</b>
7.1	Error messages (power source).....	39
7.2	Warnings .....	46
7.3	Checklist for rectifying faults .....	47

---

7.4	Vent coolant circuit.....	49
<b>8</b>	<b>Technical data .....</b>	<b>50</b>
8.1	Drive 4X S .....	50
<b>9</b>	<b>Accessories.....</b>	<b>51</b>
9.1	Welding torch cooling system.....	51
9.1.1	Coolant - type blueCool.....	51
9.2	Option for retrofitting.....	51
9.3	General accessories.....	51
<b>10</b>	<b>Replaceable parts .....</b>	<b>52</b>
10.1	Wire feed rollers.....	52
10.1.1	Wire feed rollers for steel wire.....	52
10.1.2	Wire feed rollers for aluminium wire.....	52
10.1.3	Wire feed rollers for cored wire .....	53
10.1.4	Wire guide.....	53
<b>11</b>	<b>Appendix.....</b>	<b>54</b>
11.1	Average wire electrode usage.....	54
11.2	Average shielding gas usage.....	54
11.2.1	MIG/MAG welding.....	54
11.2.2	TIG welding .....	54
11.3	Searching for a dealer.....	55

## 2 For your safety

### 2.1 Notes on using these operating instructions

#### **DANGER**

**Working or operating procedures which must be closely observed to prevent imminent serious and even fatal injuries.**

- Safety notes include the "DANGER" keyword in the heading with a general warning symbol.
- The hazard is also highlighted using a symbol on the edge of the page.

#### **WARNING**

**Working or operating procedures which must be closely observed to prevent serious and even fatal injuries.**

- Safety notes include the "WARNING" keyword in the heading with a general warning symbol.
- The hazard is also highlighted using a symbol in the page margin.

#### **CAUTION**

**Working or operating procedures which must be closely observed to prevent possible minor personal injury.**

- The safety information includes the "CAUTION" keyword in its heading with a general warning symbol.
- The risk is explained using a symbol on the edge of the page.



***Technical aspects which the user must observe to avoid material or equipment damage.***

Instructions and lists detailing step-by-step actions for given situations can be recognised via bullet points, e.g.:

- Insert the welding current lead socket into the relevant socket and lock.

## 2.2 Explanation of icons

Symbol	Description	Symbol	Description
	Indicates technical aspects which the user must observe.		Activate and release / Tap / Tip
	Switch off machine		Release
	Switch on machine		Press and hold
	Incorrect / Invalid		Switch
	Correct / Valid		Turn
	Input		Numerical value – adjustable
	Navigation		Signal light lights up in green
	Output		Signal light flashes green
	Time representation (e.g.: wait 4 s / actuate)		Signal light lights up in red
	Interruption in the menu display (other setting options possible)		Signal light flashes red
	Tool not required/do not use		Signal light lights up in blue
	Tool required/use		Signal light flashes blue

## 2.3 Safety instructions

### WARNING



**Risk of accidents due to non-compliance with the safety instructions!**  
**Non-compliance with the safety instructions can be fatal!**

- Carefully read the safety instructions in this manual!
- Observe the accident prevention regulations and any regional regulations!
- Inform persons in the working area that they must comply with the regulations!



**Risk of injury from electrical voltage!**

**Voltages can cause potentially fatal electric shocks and burns on contact. Even low voltages can cause a shock and lead to accidents.**

- Never touch live components such as welding current sockets or stick, tungsten or wire electrodes!
- Always place torches and electrode holders on an insulated surface!
- Wear the full personal protective equipment (depending on the application)!
- The machine may only be opened by qualified personnel!
- The device must not be used to defrost pipes!



**Hazard when interconnecting multiple power sources!**

**If a number of power sources are to be connected in parallel or in series, only a technical specialist may interconnect the sources as per standard IEC 60974-9:2010: Installation and use and German Accident Prevention Regulation BVG D1 (formerly VBG 15) or country-specific regulations.**

**Before commencing arc welding, a test must verify that the equipment cannot exceed the maximum permitted open circuit voltage.**

- Only qualified personnel may connect the machine.
- When taking individual power sources out of operation, all mains and welding current leads must be safely disconnected from the welding system as a whole. (Hazard due to reverse polarity voltage!)
- Do not interconnect welding machines with pole reversing switch (PWS series) or machines for AC welding since a minor error in operation can cause the welding voltages to be combined, which is not permitted.



**Risk of injury due to radiation or heat!**

**Arc radiation can lead to skin and eye injuries.**

**Contact with hot workpieces and sparks can lead to burns.**

- Use hand shield or welding helmet with the appropriate safety level (depends on the application).
- Wear dry protective clothing (e.g. hand shield, gloves, etc.) in accordance with the applicable regulations of your country.
- Persons who are not directly involved should be protected with a welding curtain or suitable safety screen against radiation and the risk of blinding!

## **WARNING**



### **Risk of injury due to improper clothing!**

**During arc welding, radiation, heat and voltage are sources of risk that cannot be avoided. The user has to be equipped with the complete personal protective equipment at all times. The protective equipment has to include:**

- Respiratory protection against hazardous substances and mixtures (fumes and vapours); otherwise implement suitable measures such as extraction facilities.
- Welding helmet with proper protection against ionizing radiation (IR and UV radiation) and heat.
- Dry welding clothing (shoes, gloves and body protection) to protect against warm environments with conditions comparable to ambient temperatures of 100 °C or higher and arcing and work on live components.
- Hearing protection against harming noise.



### **Explosion risk!**

**Apparently harmless substances in closed containers may generate excessive pressure when heated.**

- Move containers with inflammable or explosive liquids away from the working area!
- Never heat explosive liquids, dusts or gases by welding or cutting!



### **Fire hazard!**

**Due to the high temperatures, sparks, glowing parts and hot slag that occur during welding, there is a risk of flames.**

- Be watchful of potential sources of fire in the working area!
- Do not carry any easily inflammable objects, e.g. matches or lighters.
- Ensure suitable fire extinguishers are available in the working area!
- Thoroughly remove any residue of flammable materials from the workpiece prior to starting to weld.
- Only further process workpieces after they have cooled down. Do not allow them to contact any flammable materials!



**⚠ CAUTION****Smoke and gases!**

**Smoke and gases may lead to shortness of breath and poisoning! The ultraviolet radiation of the arc may also convert solvent vapours (chlorinated hydrocarbon) into poisonous phosgene.**

- Ensure sufficient fresh air!
- Keep solvent vapours away from the arc beam field!
- Wear suitable respiratory protection if necessary!
- To prevent the formation of phosgene, residues of chlorinated solvents on workpieces must first be neutralised using appropriate measures.

**Noise exposure!**

**Noise exceeding 70 dBA can cause permanent hearing damage!**

- Wear suitable ear protection!
- Persons located within the working area must wear suitable ear protection!



**According to IEC 60974-10, welding machines are divided into two classes of electromagnetic compatibility (the EMC class can be found in the Technical data) > see 8 chapter:**



**Class A** machines are not intended for use in residential areas where the power supply comes from the low-voltage public mains network. When ensuring the electromagnetic compatibility of class A machines, difficulties can arise in these areas due to interference not only in the supply lines but also in the form of radiated interference.



**Class B** machines fulfil the EMC requirements in industrial as well as residential areas, including residential areas connected to the low-voltage public mains network.

**Setting up and operating**

When operating arc welding systems, in some cases, electro-magnetic interference can occur although all of the welding machines comply with the emission limits specified in the standard. The user is responsible for any interference caused by welding.

In order to **evaluate** any possible problems with electromagnetic compatibility in the surrounding area, the user must consider the following: (see also EN 60974-10 Appendix A)

- Mains, control, signal and telecommunication lines
- Radios and televisions
- Computers and other control systems
- Safety equipment
- The health of neighbouring persons, especially if they have a pacemaker or wear a hearing aid
- Calibration and measuring equipment
- The immunity to interference of other equipment in the surrounding area
- The time of day at which the welding work must be carried out

**Recommendations for reducing interference emission**

- Mains connection, e.g. additional mains filter or shielding with a metal tube
- Maintenance of the arc welding system
- Welding leads should be as short as possible and run closely together along the ground
- Potential equalization
- Earthing of the workpiece. In cases where it is not possible to earth the workpiece directly, it should be connected by means of suitable capacitors.
- Shielding from other equipment in the surrounding area or the entire welding system

**Electromagnetic fields!**

**The power source can create electrical or electromagnetic fields that may impair the function of electronic systems such as EDP and CNC devices, telecommunication, power and signal lines as well as pacemakers and defibrillators.**



- Follow the maintenance instructions > see 6.3 chapter!
- Unwind the welding leads completely!
- Shield radiation-sensitive equipment or facilities appropriately!
- The function of pacemakers may be impaired (seek medical advice if necessary).

## CAUTION



### Obligations of the operator!

**The respective national directives and laws must be complied with when operating the machine!**

- Implementation of national legislation relating to framework directive 89/391/EEC on the introduction of measures to encourage improvements in the safety and health of workers at work and associated individual guidelines.
- In particular, directive 89/655/EEC concerning the minimum safety and health requirements for the use of work equipment by workers at work.
- The regulations applicable to occupational safety and accident prevention in the country concerned.
- Setting up and operating the machine as per IEC 60974.-9.
- Brief the user on safety-conscious work practices on a regular basis.
- Regularly inspect the machine as per IEC 60974.-4.



***The manufacturer's warranty becomes void if non-genuine parts are used!***

- ***Only use system components and options (power sources, welding torches, electrode holders, remote controls, spare parts and replacement parts, etc.) from our range of products!***
- ***Only insert and lock accessory components into the relevant connection socket when the machine is switched off.***

### Requirements for connection to the public mains network

High-performance machines can influence the mains quality by taking current from the mains network. For some types of machines, connection restrictions or requirements relating to the maximum possible line impedance or the necessary minimum supply capacity at the interface with the public network (Point of Common Coupling, PCC) can therefore apply. In this respect, attention is also drawn to the machines' technical data. In this case, it is the responsibility of the operator, where necessary in consultation with the mains network operator, to ensure that the machine can be connected.

## 2.4 Transport and installation

## WARNING



### Risk of injury due to improper handling of shielding gas cylinders!

**Improper handling and insufficient securing of shielding gas cylinders can cause serious injuries!**

- Observe the instructions from the gas manufacturer and any relevant regulations concerning the use of compressed air!
- Do not attach any element to the shielding gas cylinder valve!
- Prevent the shielding gas cylinder from heating up.

**⚠ CAUTION****Risk of accidents due to supply lines!**

During transport, attached supply lines (mains leads, control cables, etc.) can cause risks, e.g. by causing connected machines to tip over and injure persons!

- Disconnect all supply lines before transport!

**Risk of tipping!**

There is a risk of the machine tipping over and injuring persons or being damaged itself during movement and set up. Tilt resistance is guaranteed up to an angle of 10° (according to IEC 60974-1).

- Set up and transport the machine on level, solid ground.
- Secure add-on parts using suitable equipment.

**Risk of accidents due to incorrectly installed leads!**

Incorrectly installed leads (mains, control and welding leads or intermediate hose packages) can present a tripping hazard.

- Lay the supply lines flat on the floor (avoid loops).
- Avoid laying the leads on passage ways.

**Risk of injury from heated coolant and its connections!**

The coolant used and its connection or connection points can heat up significantly during operation (water-cooled version). When opening the coolant circuit, escaping coolant may cause scalding.

- Open the coolant circuit only when the power source or cooling unit is switched off!
- Wear proper protective equipment (protective gloves)!
- Seal open connections of the hose leads with suitable plugs.



***The units are designed for operation in an upright position!***

***Operation in non-permissible positions can cause equipment damage.***

- ***Only transport and operate in an upright position!***



***Accessory components and the power source itself can be damaged by incorrect connection!***

- ***Only insert and lock accessory components into the relevant connection socket when the machine is switched off.***
- ***Comprehensive descriptions can be found in the operating instructions for the relevant accessory components.***
- ***Accessory components are detected automatically after the power source is switched on.***



***Protective dust caps protect the connection sockets and therefore the machine against dirt and damage.***

- ***The protective dust cap must be fitted if there is no accessory component being operated on that connection.***
- ***The cap must be replaced if faulty or if lost!***

### 3 Intended use



**⚠ WARNING**

**Hazards due to improper usage!**

The machine has been constructed to the state of the art and any regulations and standards applicable for use in industry and trade. It may only be used for the welding procedures indicated at the rating plate. Hazards may arise for persons, animals and material objects if the equipment is not used correctly. No liability is accepted for any damages arising from improper usage!

- The equipment must only be used in line with its designated purpose and by trained or expert personnel!
- Do not improperly modify or convert the equipment!

#### 3.1 Applications

Wire feeder to feed wire electrodes for gas-shielded metal-arc welding.

#### 3.2 Use and operation solely with the following machines

**A suitable power source (system component) is required in order to operate the wire feed unit!**

The following system components can be combined with this machine:

<b>Power source</b>	Sirion 405 puls D Sirion 505 puls D
<b>Wire feed unit</b>	Drive 4X S
<b>Transport vehicle</b>	Trolly 54-5

#### 3.3 Documents which also apply

##### 3.3.1 Warranty

For more information refer to the "Warranty registration" brochure supplied and our information regarding warranty, maintenance and testing at [www.ewm-group.com](http://www.ewm-group.com)!

##### 3.3.2 Declaration of Conformity



This product corresponds in its design and construction to the EU directives listed in the declaration. The product comes with a relevant declaration of conformity in the original.

The manufacturer recommends carrying out the safety inspection according to national and international standards and guidelines every 12 months (from commissioning).

##### 3.3.3 Service documents (spare parts and circuit diagrams)



**⚠ WARNING**

**No improper repairs and modifications!**

**To prevent injuries and damage to the machine, only competent personnel (authorised service personnel) are allowed to repair or modify the machine.**

**Unauthorised manipulations will invalidate the warranty!**

- Instruct competent personnel (authorised service personnel) to repair the machine.

Original copies of the circuit diagrams are enclosed with the unit.

Spare parts can be obtained from the relevant authorised dealer.

##### 3.3.4 Calibration/Validation

An original certificate is enclosed with the product. The manufacturer recommends calibration / validation at intervals of 12 months (from commissioning).

### 3.3.5 Part of the complete documentation

This document is part of the complete documentation and valid only in combination with all other parts of these instructions! Read and observe the operating instructions for all system components, especially the safety instructions!

The illustration shows a general example of a welding system.

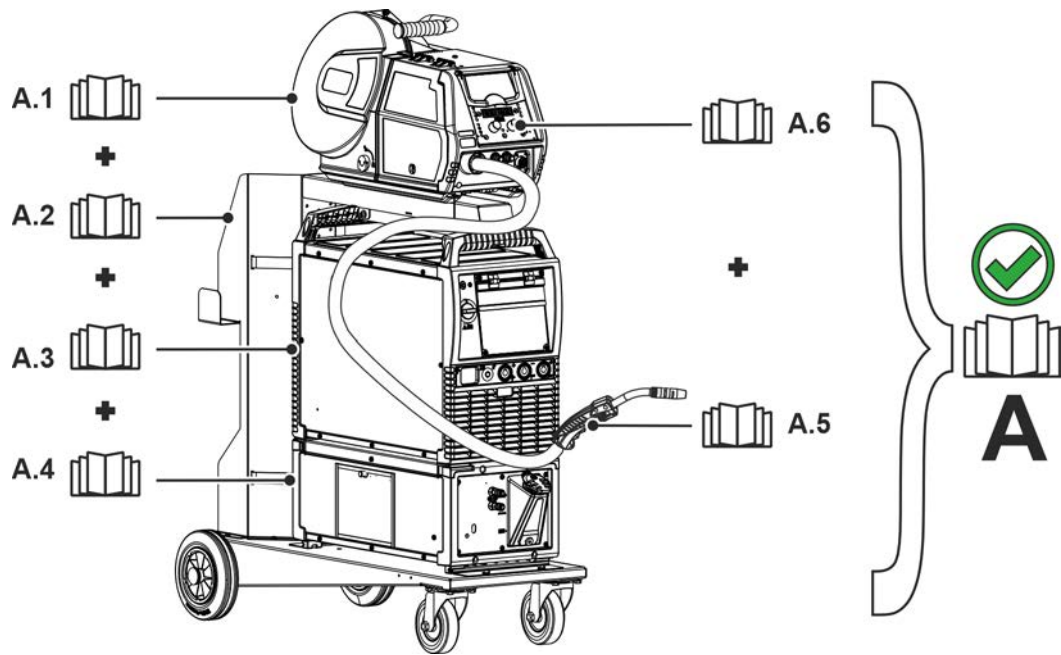

Figure 3-1

Item	Documentation
A.1	Wire feed unit
A.2	Transport vehicle
A.3	Power source
A.4	Cooling unit
A.5	Welding torch
A.6	Control
A	Complete documentation

## 4 Machine description – quick overview

### 4.1 Front view / side view from the right

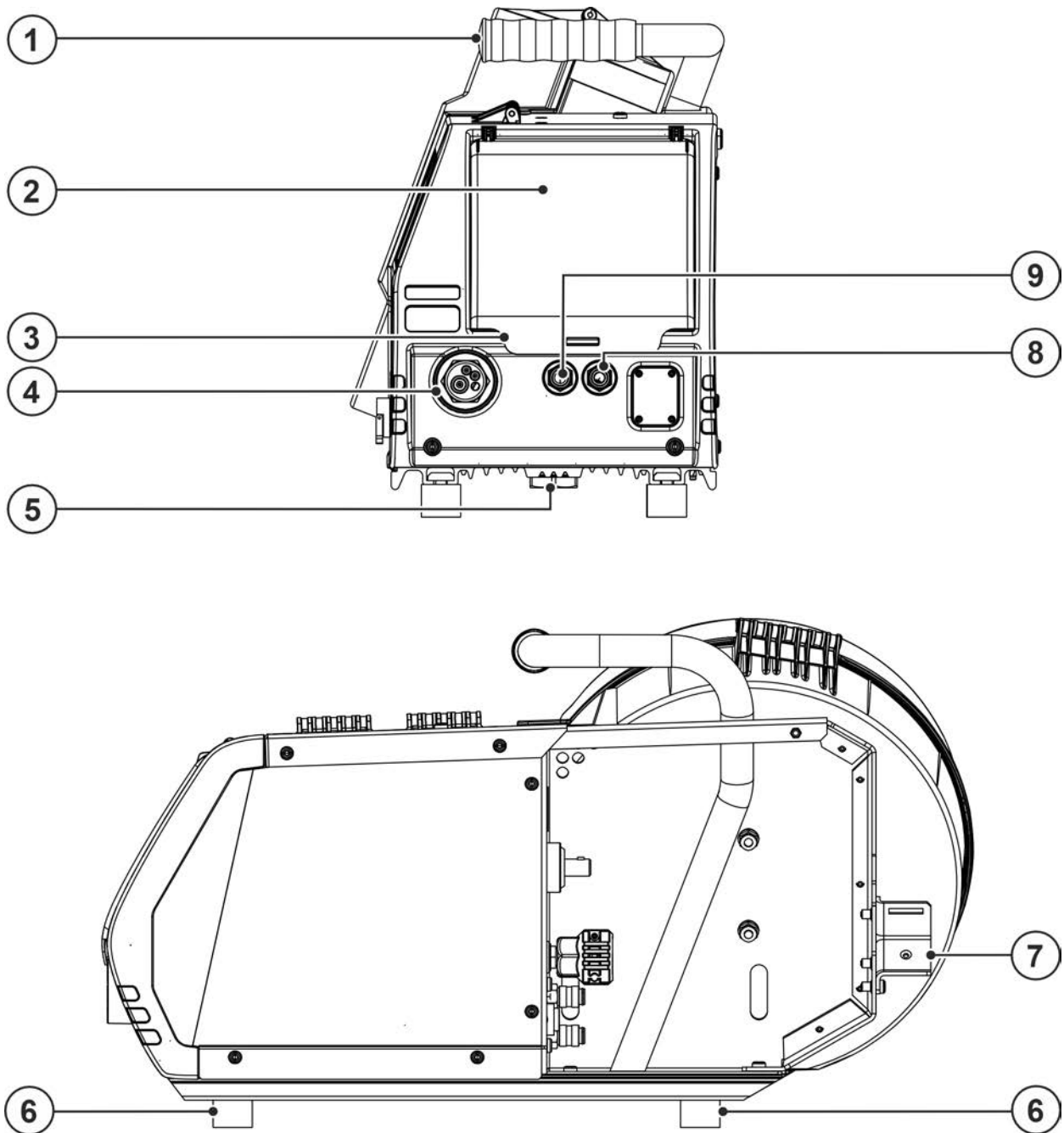



Figure 4-1

Item	Symbol	Description
1		Carrying handle
2		Machine control (see the relevant control operating instructions)
3		Protective cap, welding machine control > see 5.2.3 chapter
4		Welding torch connection (Euro or Dinse torch connector) Welding current, shielding gas and torch trigger integrated
5		Turning mandrel support The wire feeder is placed onto the power source turning mandrel using this support to enable horizontal pivoting of the machine.
6		Machine feet
7		Intermediate hose package strain relief > see 5.2 chapter
8		Rear view / side view from the left > see 4.2 chapter
9		Quick connect coupling (red) coolant return
10		Quick connect coupling (blue) coolant supply

## 4.2 Rear view / side view from left

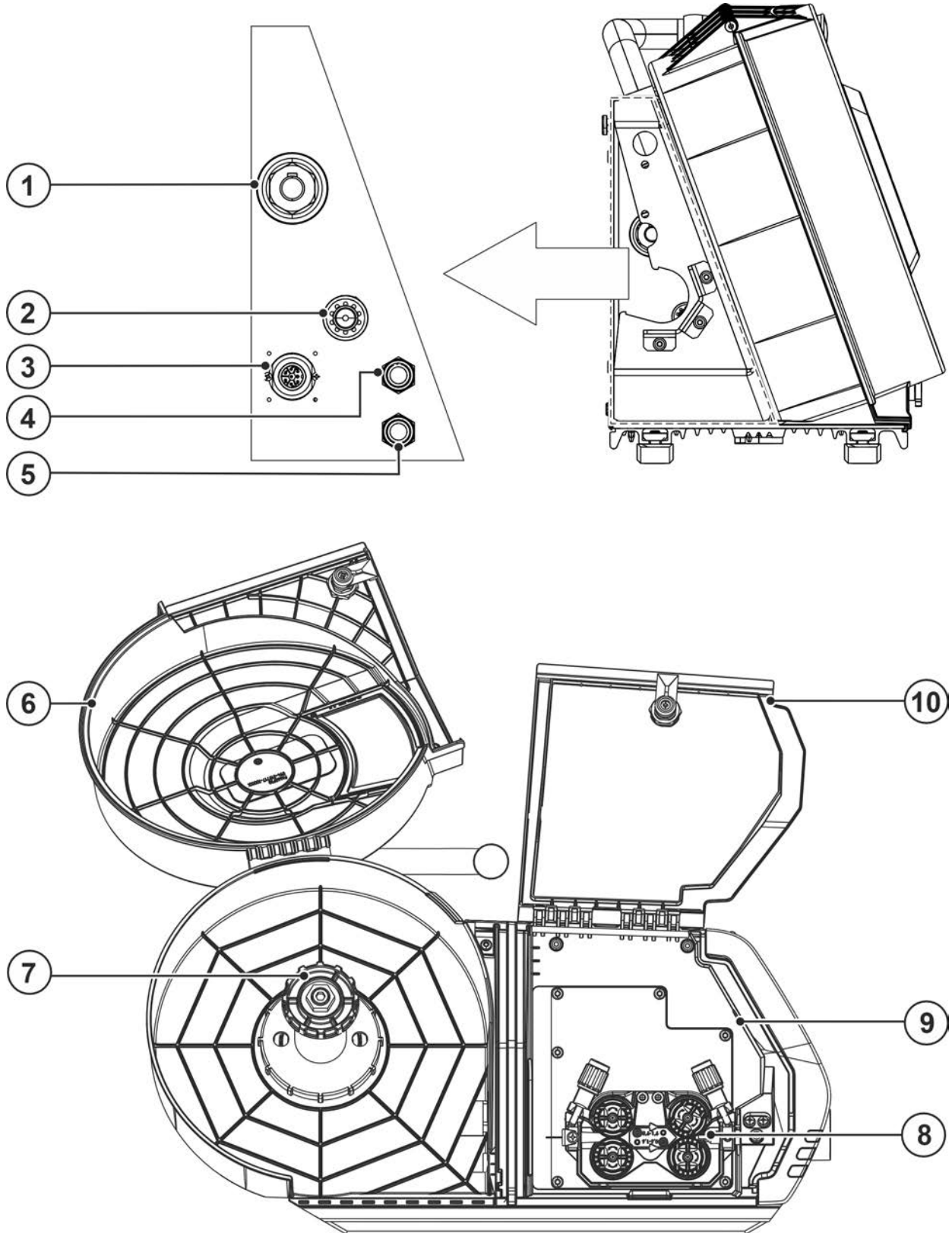







Figure 4-2



Item	Symbol	Description
1		<b>Power source welding current connector plug</b> Welding current connection between power source and wire feeder
2		<b>Connection thread - G<math>\frac{1}{4}</math>"</b> Shielding gas connection (inlet)
3		<b>7-pole connection socket (digital)</b> • Control lead for wire feed unit
4		<b>Quick connect coupling (red)</b> coolant return
5		<b>Quick connect coupling (blue)</b> coolant supply
6		<b>Wire spool protective cap</b>
7		<b>Wire spool holder</b>
8		<b>Wire feed unit &gt; see 5.3.3 chapter</b>
9		<b>Lighting, inside</b>
10		<b>Protective cap, wire feed mechanism</b> On the inside of the protective cap the welding task lists (JOB-List) for the relevant welding machine series can be found.

## 5 Design and function

### **WARNING**



**Risk of injury from electrical voltage!**

**Contact with live parts, e.g. power connections, can be fatal!**

- Observe the safety information on the first pages of the operating instructions!
- Commissioning must be carried out by persons who are specifically trained in handling power sources!
- Connect connection or power cables while the machine is switched off!

### **CAUTION**

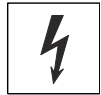

**Risk from electrical current!**

**If welding is carried out alternately using different methods and if a welding torch and an electrode holder remain connected to the machine, the open-circuit/welding voltage is applied simultaneously on all cables.**

- The torch and the electrode holder should therefore always be placed on an insulated surface before starting work and during breaks.

**Read and observe the documentation to all system and accessory components!**

## 5.1 Transport and installation

### **WARNING**



**Risk of accident due to improper transport of machines that must not be lifted!**

**Do not lift or suspend the machine! The machine can drop and cause injuries! The handles, straps or brackets are suitable for transport by hand only!**

- The machine must not be suspended or lifted using a crane.
- Depending on machine type, equipment for lifting by crane or use while suspended is available as a retrofitting option > see 9 chapter.

### 5.1.1 Ambient conditions



**The machine must not be operated in the open air and must only be set up and operated on a suitable, stable and level base!**

- The operator must ensure that the ground is non-slip and level, and provide sufficient lighting for the place of work.
- Safe operation of the machine must be guaranteed at all times.



**Machine damage due to contamination!**

**Unusually high amounts of dust, acid, corrosive gas or substances may damage the machine (note the maintenance intervals > see 6.3 chapter).**

- Prevent high amounts of smoke, weld spatter, steam, oil vapour, grinding dust and corrosive ambient air from developing!

#### In operation

Temperature range of the ambient air:

- -25 °C to +40 °C (-13 °F to 104 °F) <sup>[1]</sup>

Relative humidity:

- up to 50 % at 40 °C (104 °F)
- up to 90 % at 20 °C (68 °F)

## Transport and storage

Storage in a closed room, temperature range of the ambient air:

- -30 °C to +70 °C (-22 °F to 158 °F) <sup>[1]</sup>

Relative humidity

- up to 90 % at 20 °C (68 °F)

<sup>[1]</sup> Ambient temperature dependent on coolant! Observe the coolant temperature range of the torch cooling

### 5.1.2 Workpiece lead, general

#### CAUTION



**Risk of burning due to incorrect welding current connection!**

**If the welding current plugs (machine connections) are not locked or if the workpiece connection is contaminated (paint, corrosion), these connections and leads can heat up and cause burns when touched!**

- Check welding current connections on a daily basis and lock by turning to the right when necessary.
- Clean workpiece connection thoroughly and secure properly. Do not use structural parts of the workpiece as welding current return lead!

### 5.1.3 Welding torch cooling system



**Material damage due to unsuitable coolants!**

**Unsuitable coolant, coolants mixed with other types / liquids or use in an unsuitable temperature range will result in material damage and loss of the manufacturer's warranty!**

- **Operation without coolant is not permitted! Dry running will destroy the cooling components such as the coolant pump, welding torch and hose packages.**
- **Only use the coolants described in these instructions for the specified ambient conditions (temperature range) > see 5.1.3.1 chapter.**
- **Do not mix coolants of different types (including those described in these instructions).**
- **When changing the coolant, all liquid must be replaced and the cooling system flushed.**

Dispose of the coolant in accordance with local regulations and the material safety data sheets.

#### 5.1.3.1 Permitted torch coolant

Coolant	Temperature range
blueCool -10	-10 °C to +40 °C (14 °F to +104 °F)
KF 23E	-10 °C to +40 °C (14 °F to +104 °F)
KF 37E	-20 °C to +30 °C (-4 °F to +86 °F)
blueCool -30	-30 °C to +40 °C (-22 °F to +104 °F)

## 5.1.3.2 Maximal hose package length

All information relates to the total hose package length of the complete welding system and presents exemplary configurations (of components of the EWM product portfolio with standard lengths). A straight kink-free installation is to be ensured, taking into account the max. delivery height.

**Pump: Pmax = 3,5 bar (0.35 MPa)**

Power source	Hose package	Wire feeder	miniDrive	Welding torch	Max.
Compact	✗	✗	✓ (25 m / 82 ft.)	✓ (5 m / 16 ft.)	30 m 98 ft.
	✓ (20 m / 65 ft.)	✓	✗	✓ ✓ (5 m / 16 ft.)	
Decompact	✓ (25 m / 82 ft.)	✓	✗	✓ (5 m / 16 ft.)	
	✓ (15 m / 49 ft.)	✓	✓ (10 m / 32 ft.)	✓ (5 m / 16 ft.)	

**Pump: Pmax = 4.5 bar (0.45 MPa)**

Power source	Hose package	Wire feeder	miniDrive	Welding torch	Max.
Compact	✗	✗	✓ (25 m / 82 ft.)	✓ (5 m / 16 ft.)	30 m 98 ft.
	✓ (30 m / 98 ft.)	✓	✗	✓ ✓ (5 m / 16 ft.)	40 m 131 ft.
Decompact	✓ (40 m / 131 ft.)	✓	✗	✓ (5 m / 16 ft.)	45 m 147 ft.
	✓ (40 m / 131 ft.)	✓	✓ (25 m / 82 ft.)	✓ (5 m / 16 ft.)	70 m 229 ft.

## 5.1.4 Notes on the installation of welding current leads

- Incorrectly installed welding current leads can cause faults in the arc (flickering).
- Lay the workpiece lead and hose package of power sources without HF igniter (MIG/MAG) for as long and as close as possible in parallel.
- Lay the workpiece lead and hose package of power sources with HF igniter (TIG) for as long as possible in parallel with a distance of 20 cm to avoid HF sparkover.
- Always keep a distance of at least 20 cm to leads of other power sources to avoid interferences
- Always keep leads as short as possible! For optimum welding results max. 30 m (welding lead + intermediate hose package + torch lead).

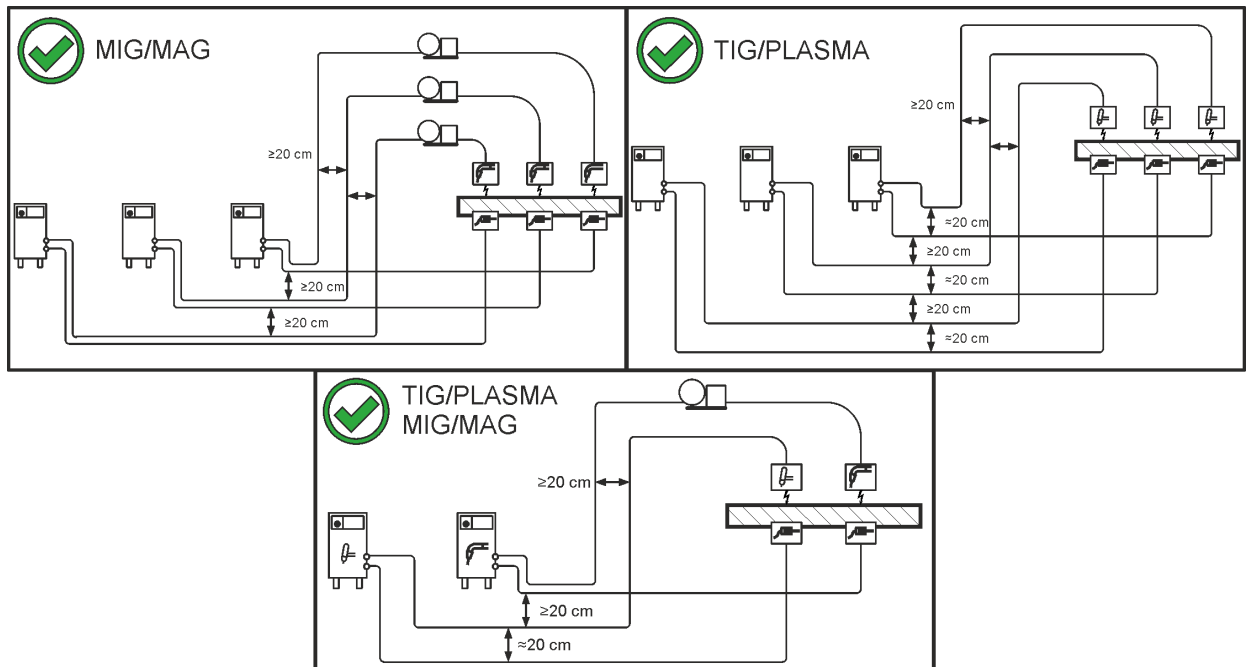

Figure 5-1

- Use an individual welding lead to the workpiece for each welding machine!

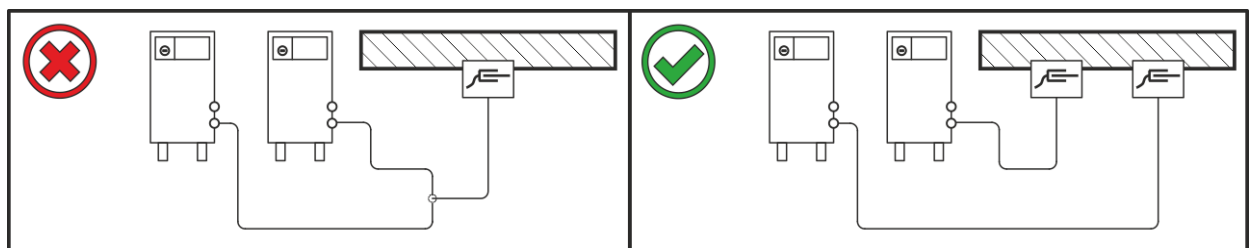

Figure 5-2

- Fully unroll welding current leads, torch hose packages and intermediate hose packages. Avoid loops!
- Always keep leads as short as possible!

Lay any excess cable lengths in meanders.

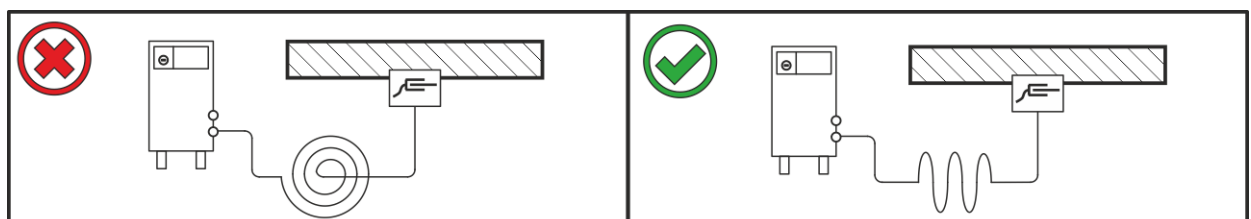

Figure 5-3

## 5.1.5 Stray welding currents

### ⚠ WARNING



**Risk of injury due to stray welding currents!**

**Stray welding currents can destroy protective earth conductors, damage machines and electronic devices and cause overheating of components, leading to fire.**

- Check that all welding current connections are firmly secured and electrical connections are in perfect condition.
- Set up, attach or suspend all conductive power source components such as casing, transport vehicles and crane frames so they are insulated.
- Do not place any other electronic devices such as drills or angle grinders on the power source, transport vehicle or crane frames unless they are insulated.
- Always put welding torches and electrode holders on an insulated surface when they are not in use.

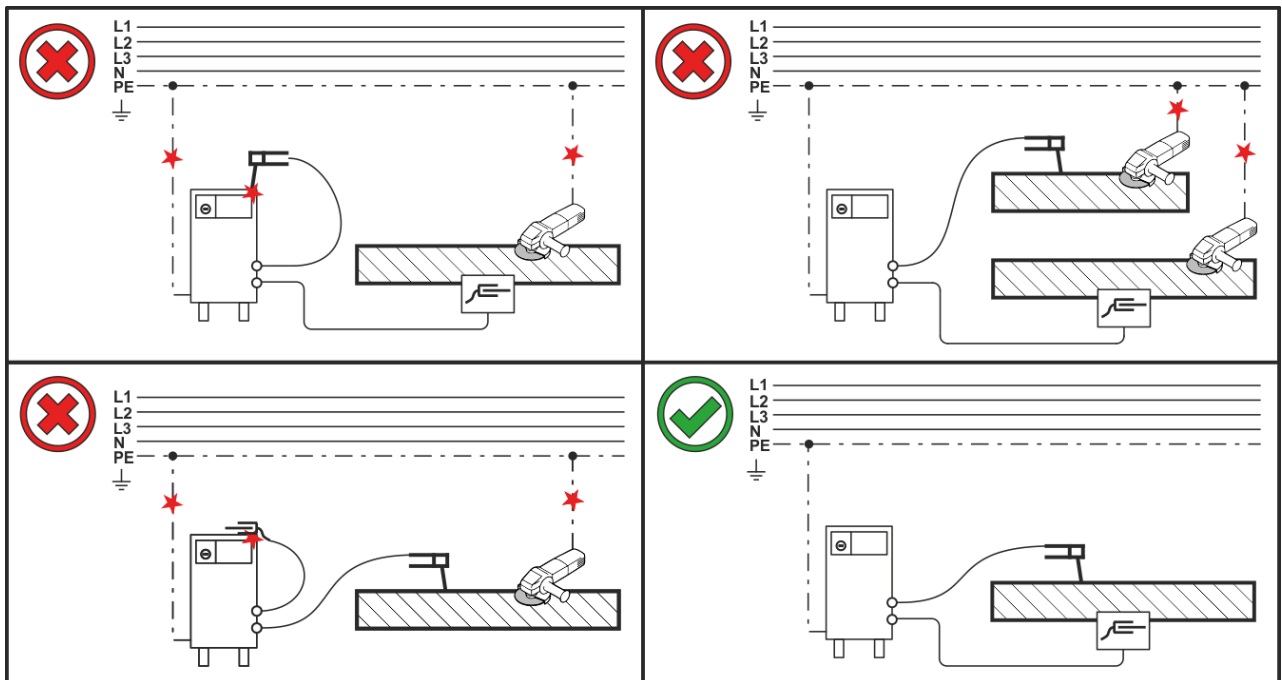

Figure 5-4

## 5.2 Intermediate hose package connection

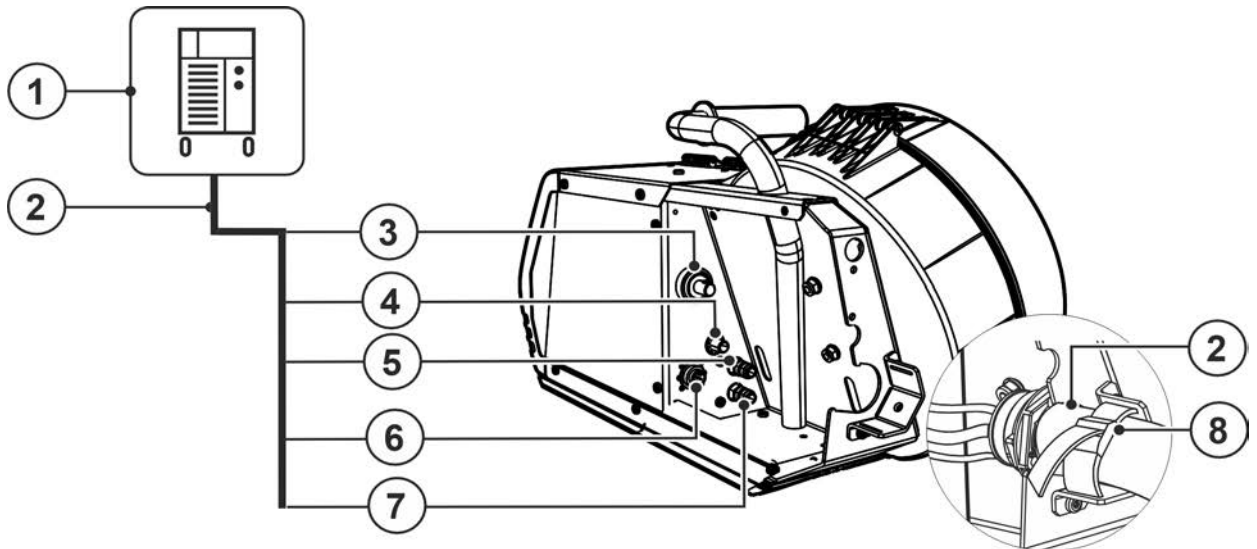

Figure 5-5

Item	Symbol	Description
1		<b>Power source</b>
2		<b>Intermediate hose package</b>
3		<b>Power source welding current connector plug</b> Welding current connection between power source and wire feeder
4		<b>Connection thread - G 1/4"</b> Shielding gas connection (inlet)
5		<b>Quick connect coupling (red)</b> coolant return
6		<b>7-pole connection socket (digital)</b> • Control lead for wire feed unit
7		<b>Quick connect coupling (blue)</b> coolant supply
8		<b>Safety belt</b> Intermediate hose package strain relief

- Secure hose package end with the strain relief > see 5.2.1 chapter.
- Push the welding current cable socket onto the “welding current connecting plug” and lock by turning to the right.
- Screw the gas hose connection to the shielding gas connection (inlet) on the machine gas-tight.
- Insert cable plug on the control lead into the 7-pole connection socket and secure with crown nut (the plug can only be inserted into the connection socket in one position).
- Lock connecting nipples of the cooling water tubes into the corresponding quick connect couplings: Return line red to quick connect coupling, red (coolant return) and supply line blue to quick connect coupling, blue (coolant supply).

## 5.2.1 Intermediate hose package strain relief



**Property damage due to strain relief not installed or not installed correctly!**

**The strain relief absorbs tensile forces on cables, plugs and sockets.**

**If strain reliefs are not installed or not installed correctly, the connector plugs or sockets may be damaged.**

- **The attachment must always take place on both sides of the intermediate hose package!**
- **The connections of the hose package must be locked properly!**

### 5.2.1.1 Locking the strain relief

EWM intermediate hose package

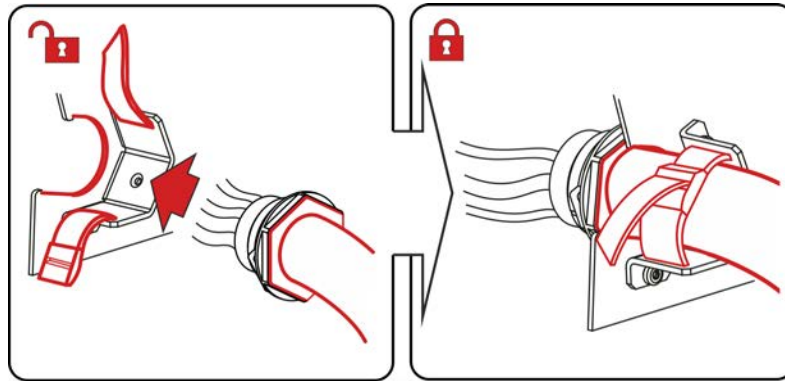

Figure 5-6

## 5.2.2 Shielding gas supply (shielding gas cylinder for welding machine)

### ⚠ WARNING



**Risk of injury due to improper handling of shielding gas cylinders! Improper handling and insufficient securing of shielding gas cylinders can cause serious injuries!**

- Place shielding gas cylinder into the designated holder and secure with fastening elements (chain/belt)!
- Attach the fastening elements within the upper half of the shielding gas cylinder!
- The fastening elements must tightly enclose the shielding gas cylinder!



**An unhindered shielding gas supply from the shielding gas cylinder to the welding torch is a fundamental requirement for optimum welding results. In addition, a blocked shielding gas supply may result in the welding torch being destroyed.**

- **Always re-fit the yellow protective cap when not using the shielding gas connection.**
- **All shielding gas connections must be gas tight.**

### 5.2.2.1 Pressure regulator connection

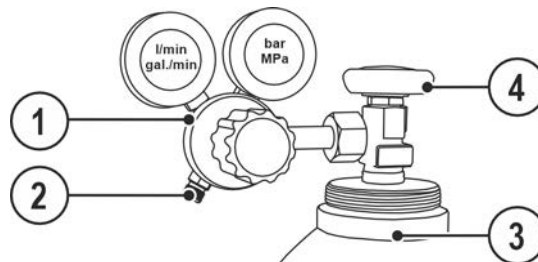

Figure 5-7

Item	Symbol	Description
1		Pressure regulator
2		Output side of the pressure regulator
3		Shielding gas cylinder



Item	Symbol	Description
4		Cylinder valve

- Before connecting the pressure regulator to the gas cylinder, open the cylinder valve briefly to blow out any dirt.
- Tighten the pressure regulator screw connection on the gas bottle valve to be gas-tight.
- Screw the gas hose connection to the outlet side of the pressure regulator gas-tight.

### 5.2.2.2 Gas test – setting the shielding gas volume

- Slowly open the gas cylinder valve.
- Open the pressure regulator.
- Switch on the power source at the main switch.
- Trigger gas test function (welding voltage and wire feed motor remain switched off – no accidental arc ignition).
- Set the relevant gas quantity for the application on the pressure regulator.

Welding process	Recommended shielding gas quantity
MAG welding	Wire diameter x 11.5 = l/min
MIG brazing	Wire diameter x 11.5 = l/min
MIG welding (aluminium)	Wire diameter x 13.5 = l/min (100 % argon)

#### Helium-rich gas mixtures require a higher gas volume!

The table below can be used to correct the gas volume calculated where necessary:

Shielding gas	Factor
75% Ar/25% He	1.14
50% Ar/50% He	1.35
25% Ar/75% He	1.75
100% He	3.16

If the shielding gas setting is too low or too high, this can introduce air to the weld pool and may cause pores to form. Adjust the shielding gas quantity to suit the welding task!

### 5.2.2.3 Setting the shielding gas volume (gas test)/rinse hose package

- Slowly open the gas cylinder valve.
- Open the pressure regulator.
- Switch on the power source at the main switch.
- Set the relevant gas quantity for the application on the pressure regulator.
- The gas test can be activated at the machine control by pressing the Gas test  push-button > see 4 chapter.

Shielding gas flows for around 25 seconds or until the button is pressed again.

If the shielding gas setting is too low or too high, this can introduce air to the weld pool and may cause pores to form. Adjust the shielding gas quantity to suit the welding task!

Welding process	Recommended shielding gas quantity
MAG welding	Wire diameter x 11.5 = l/min
MIG brazing	Wire diameter x 11.5 = l/min
MIG welding (aluminium)	Wire diameter x 13.5 = l/min (100 % argon)

#### Helium-rich gas mixtures require a higher gas volume!

The table below can be used to correct the gas volume calculated where necessary:

Shielding gas	Factor
75% Ar/25% He	1.14
50% Ar/50% He	1.35
25% Ar/75% He	1.75
100% He	3.16

## 5.2.3 Protective flap, welding machine control

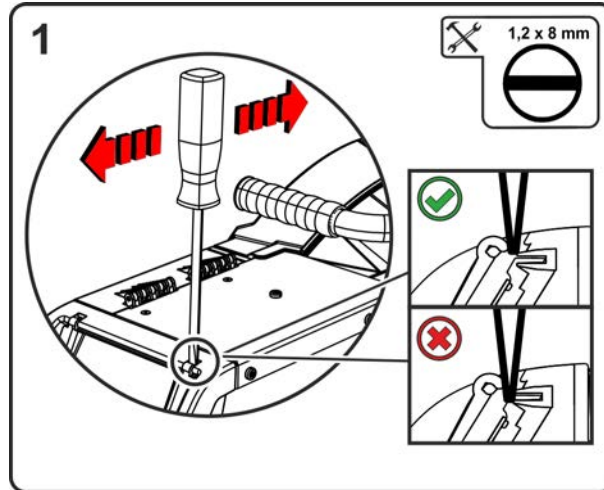

Figure 5-8

Item	Symbol	Description
1		Protective cap

- Carefully click the suspension of the protective cap towards front top.

## 5.3 MIG/MAG welding

### 5.3.1 Assemble the wire guide

The Euro torch connector is factory-fitted with a guide tube for welding torches with steel liner. Conversion is necessary if a welding torch with a steel liner is used!

- Operate welding torches with a liner > with a guide tube!
- Operate welding torches with a steel liner > with a capillary tube!

**Depending on the wire electrode diameter or type, either a steel liner or liner with the correct inner diameter must be inserted in the torch!**

Recommendation:

- Use a steel liner when welding hard, unalloyed wire electrodes (steel).
- Use a chrome nickel liner when welding hard, high-alloy wire electrodes (CrNi).
- Use a plastic or teflon liner when welding or brazing soft wire electrodes, high-alloy wire electrodes or aluminium materials.

**Preparation for connecting welding torches with a spiral guide:**

- Check that the capillary tube is correctly positioned in relation to the central connector!

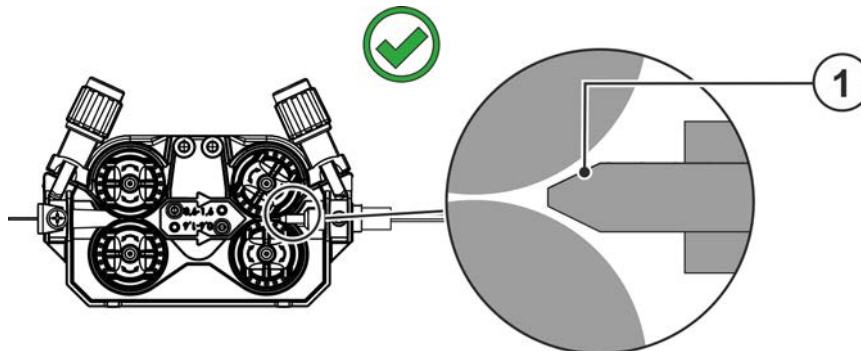

Figure 5-9

Item	Symbol	Description
1		Capillary tube > see 10 chapter

### Preparation for connecting welding torches with a liner:

- Push forward the capillary tube on the wire feed side in the direction of the Euro torch connector and remove it there.
- Insert the liner guide tube from the Euro torch connector side.
- Carefully insert the welding torch connector with as yet too long a liner into the Euro torch connector and secure with a crown nut.
- Cut off the liner with a liner cutter > see 9 chapter just before the wire feed roller.
- Loosen the welding torch connector and remove.
- Carefully chamfer the cut off end of the liner with a liner sharpener > see 9 chapter and sharpen.

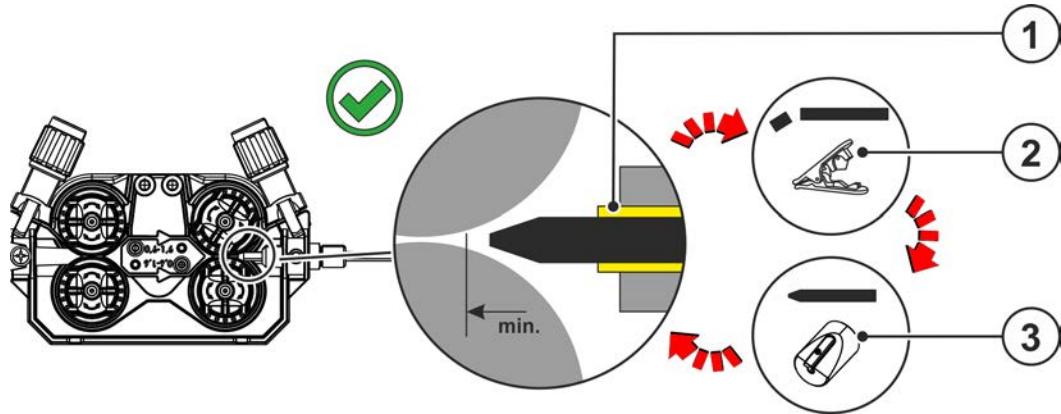

Figure 5-10

Item	Symbol	Description
1		Guide tube > see 5.3.1 chapter
2		Hose cutter > see 9 chapter
3		Liner sharpener > see 9 chapter

## 5.3.2 Welding torch connection



**Equipment damage due to improperly connected coolant pipes!**

**If the coolant pipes are not properly connected or a gas-cooled welding torch is used, the coolant circuit is interrupted and equipment damage can occur.**

- **Connect all coolant pipes correctly!**
- **Completely unroll the hose package and the torch hose package!**
- **Observe maximal hose package length > see 5.1.3.2 chapter.**
- **When using a gas-cooled welding torch, use a hose bridge to establish the coolant circuit > see 9 chapter.**

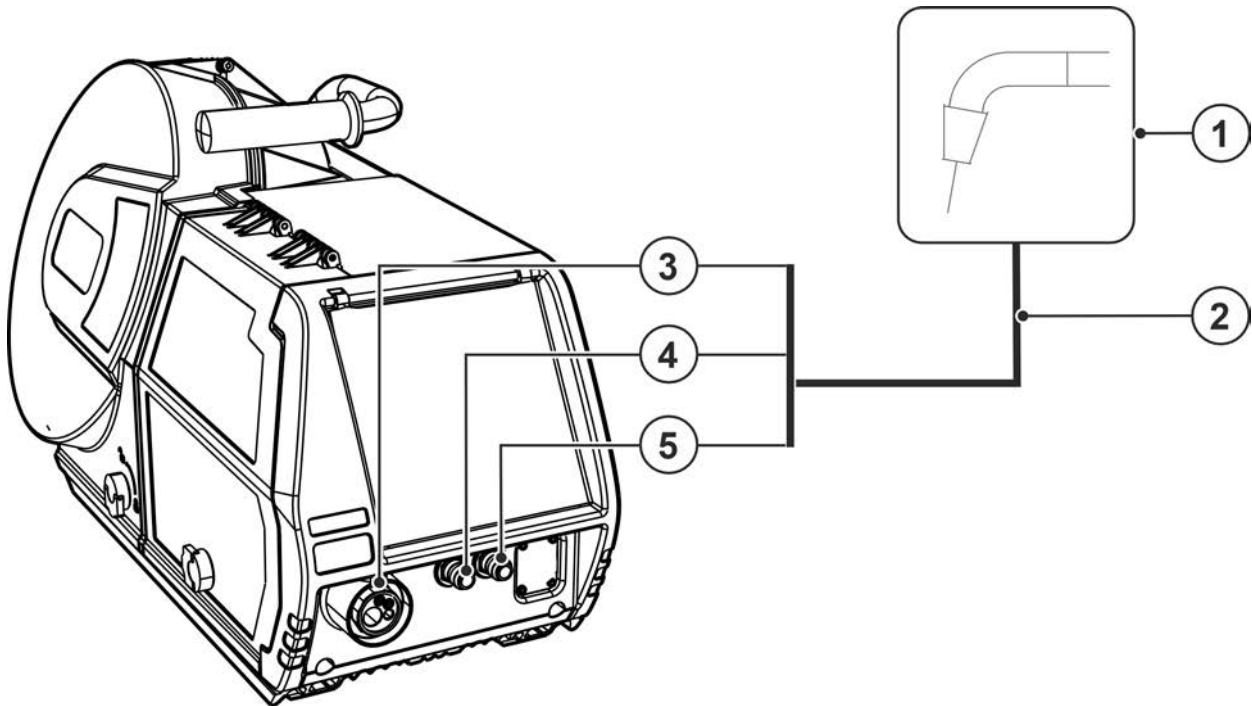

Figure 5-11

Item	Symbol	Description
1		<b>Welding torch</b>
2		<b>Welding torch hose package</b>
3		<b>Welding torch connection (Euro torch connector)</b> Welding current, shielding gas and torch trigger integrated
4		<b>Quick connect coupling (blue)</b> coolant supply
5		<b>Quick connect coupling (red)</b> coolant return

- Insert the central plug for the welding torch into the central connector and screw together with crown nut.
- Lock connecting nipples of the cooling water tubes into the corresponding quick connect couplings: Return line red to quick connect coupling, red (coolant return) and supply line blue to quick connect coupling, blue (coolant supply).

### 5.3.3 Wire feed

**⚠ CAUTION**



**Risk of injury due to moving parts!**

The wire feeders are equipped with moving parts, which can trap hands, hair, clothing or tools and thus injure persons!

- Do not reach into rotating or moving parts or drive components!
- Keep casing covers or protective caps closed during operation!



**Risk of injury due to welding wire escaping in an unpredictable manner!**

Welding wire can be conveyed at very high speeds and, if conveyed incorrectly, may escape in an uncontrolled manner and injure persons!

- Before mains connection, set up the complete wire guide system from the wire spool to the welding torch!
- Check wire guide at regular intervals!
- Keep all casing covers or protective caps closed during operation!

#### 5.3.3.1 Inserting the wire spool

**⚠ CAUTION**



**Risk of injury due to incorrectly secured wire spool.**

If the wire spool is not secured properly, it may come loose from the wire spool support and fall to the ground, causing damage to the machine and injuries.

- Make sure to correctly fasten the wire spool to the wire spool support.
- Before you start working, always check the wire spool is securely fastened.

Standard D300 wire spool holder can be used. Adapters are required when using standardised basket coils (DIN 8559) > see 9 chapter.

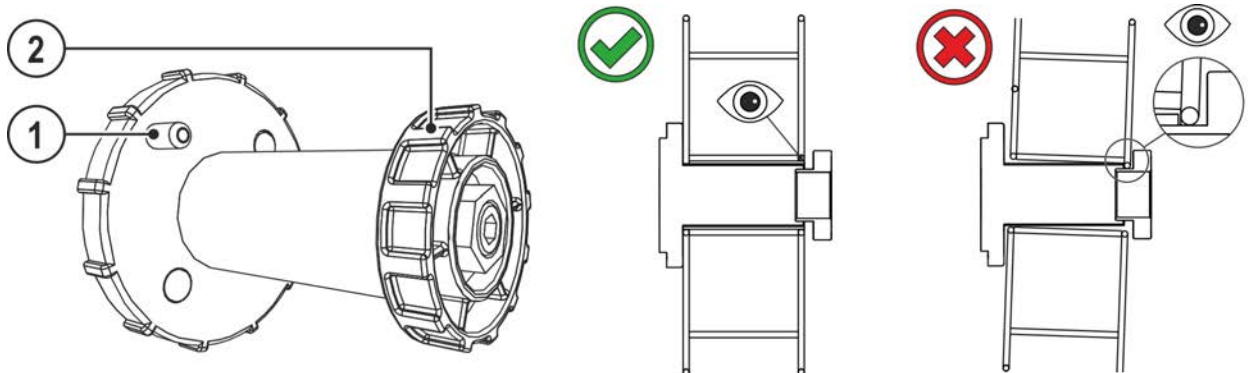

Figure 5-12

Item	Symbol	Description
1		<b>Carrier pin</b> For fixing the wire spool
2		<b>Knurled nut</b> For fixing the wire spool

- Unlock and open protective flap.
- Loosen knurled nut from spool holder.
- Fix welding wire reel onto the spool holder so that the carrier pin locks into the spool bore.
- Fasten wire spool using knurled nut.

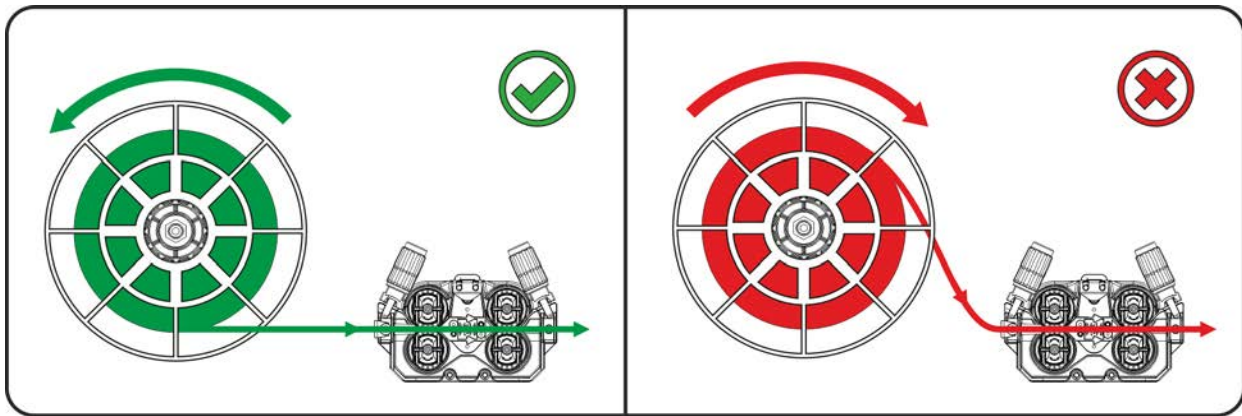

Figure 5-13

Observe the unwinding direction of the wire spool.

5.3.3.2 Changing the wire feed rollers

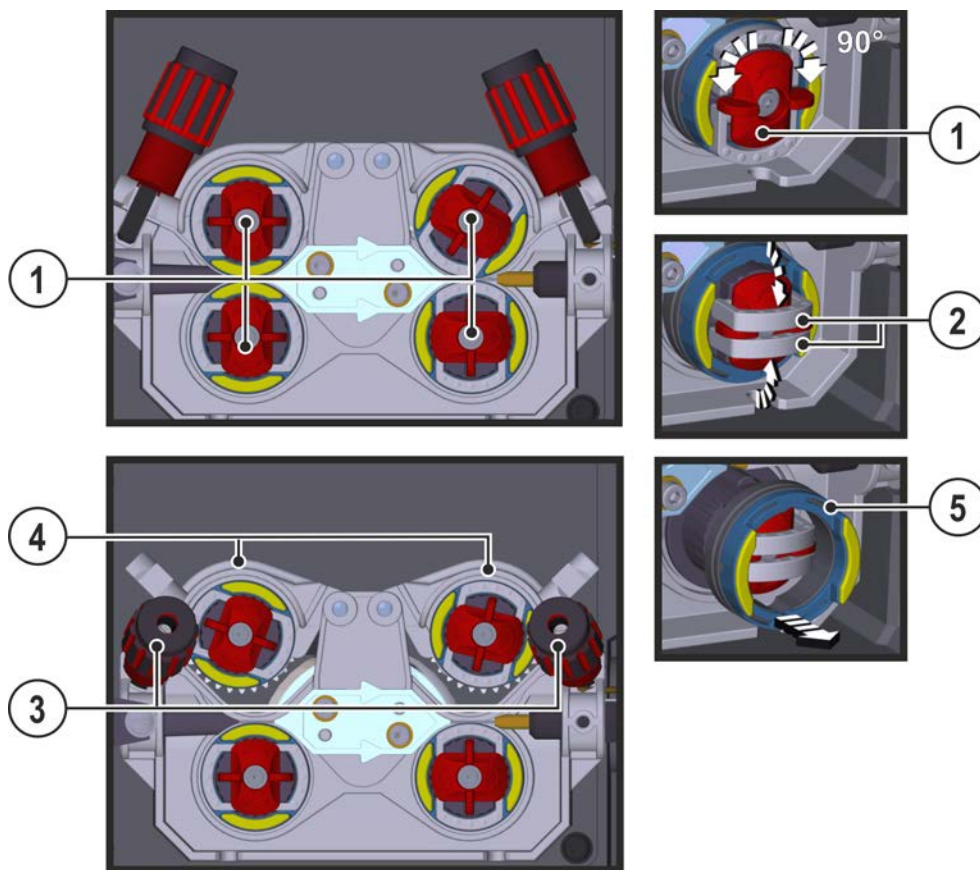

Figure 5-14

Item	Symbol	Description
1		<b>Tommy</b> The tommy is used to secure the closure brackets of the wire feed rollers.
2		<b>Closure bracket</b> The closure brackets are used to secure the wire feed rollers.
3		<b>Feed roll tensioner</b> Fixing the clamping unit and setting the pressure.
4		<b>Clamping unit</b>
5		<b>Wire feed roller</b> see the Wire feed roller overview table

- Rotate the tommy by 90° clockwise or anti-clockwise (tommy locks into place).
- Fold the closure brackets outwards by 90°.
- Unfasten pressure units and fold out (clamping units and pressure rollers will automatically flip upwards).
- Remove the wire feed rollers from the roller support.
- Select new wire feed rollers according to the Wire feed roller overview table and reassemble the wire feed mechanism in reverse order.

## Unsatisfactory welding results due to faulty wire feeding!

The wire feed rolls must be suitable for the diameter of the wire and the material. The wire feed rolls are colour-coded to facilitate distinction (see the Wire feed roll overview table). When working with a wire diameter of > 1.6 mm the drive has to be converted for the wire feed kit ON WF 2,0-3,2MM EFEED > see 10 chapter.

Wire feed roll overview table:

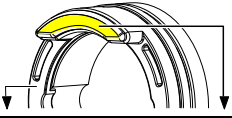
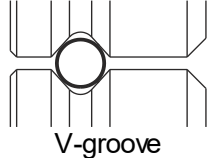
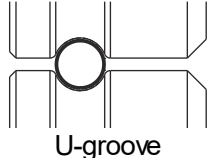
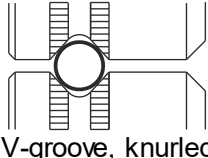
Material	Diameter		Colour code			Groove form
	Ø mm	Ø inch				
Steel Stainless steel Brazing	0.6	.024	monochrome	light pink	-	 V-groove
	0.8	.031		white		
	0.8	.031	bicolour	white	blue	
	0.9	.035				
	1.0	.039				
	1.0	.039		blue	red	
	1.2	.047				
	1.4	.055	monochrome	green	-	
	1.6	.063		black		
	2.0	.079		grey		
2.4	.094	brown				
2.8	.110	light green				
3.2	.126	purple				
Aluminium	0.8	.031	bicolour	white	yellow	 U-groove
	0.9	.035		blue		
	1.0	.039				
	1.2	.047		red		
	1.6	.063		black		
	2.0	.079		grey		
	2.4	.094		brown		
	2.8	.110		light green		
	3.2	.126		purple		
Flux cored wire	0.8	.031	bicolour	white	orange	 V-groove, knurled
	0.9	.035		blue		
	1.0	.039				
	1.2	.047		red		
	1.4	.055		green		
	1.6	.063		black		
	2.0	.079		grey		
	2.4	.094		brown		



### 5.3.3.3 Inching the wire electrode

#### ⚠ CAUTION



**Risk of injury due to welding wire escaping from the welding torch!**  
**The welding wire can escape from the welding torch at high speed and cause bodily injury including injuries to the face and eyes!**

- Never direct the welding torch towards your own body or towards other persons!



**Improper contact pressure increases wear on the wire feed rolls.**

**Adjust the contact pressure on the adjusting nuts of the feed roll tensioners so that the wire electrode is fed but slips when the wire spool is blocked.**

The inching speed is infinitely adjustable by simultaneously pressing the wire inching push-button and turning the wire speed rotary knob. The left display shows the wire feed speed selected, the right display shows the current motor current of the wire feed mechanism.

Depending on the design of the device, the wire feed mechanism may be reversed!

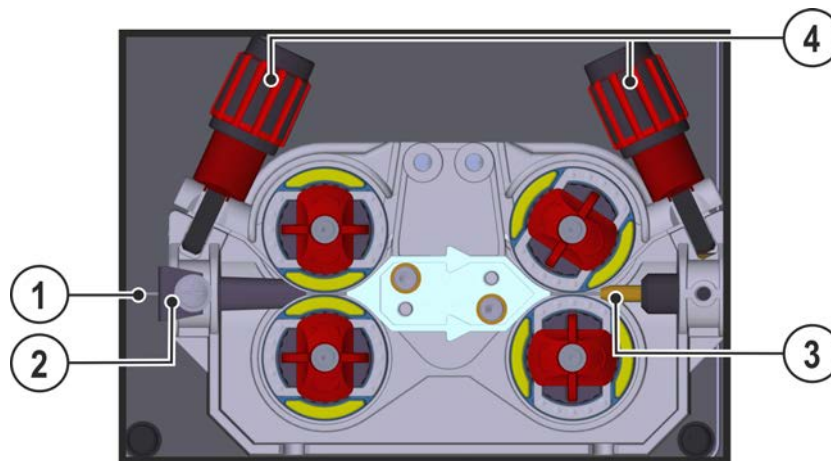

Figure 5-15

Item	Symbol	Description
1		Welding wire
2		Wire feed nipple
3		Guide tube
4		Adjusting nut

- Extend and lay out the torch hose package.
- Carefully unwind the welding wire from the wire spool and insert through the wire feed nipples up to the wire feed rollers.
- Press the inching push-button (the drive catches the welding wire and automatically guides it to the welding torch outlet) > see 4.2 chapter.

**A prerequisite for the automatic inching process is the correct preparation of the wire guide, especially in the capillary and wire guide tube area > see 5.3.1 chapter.**

- The contact pressure has to be adjusted separately for each side (wire inlet/outlet) at the feed roll tensioner setting nuts depending on the welding consumable used. A table with the setting values can be found on a sticker near the wire drive.

### Version 1: right hand mounting

### Version 2: left hand mounting

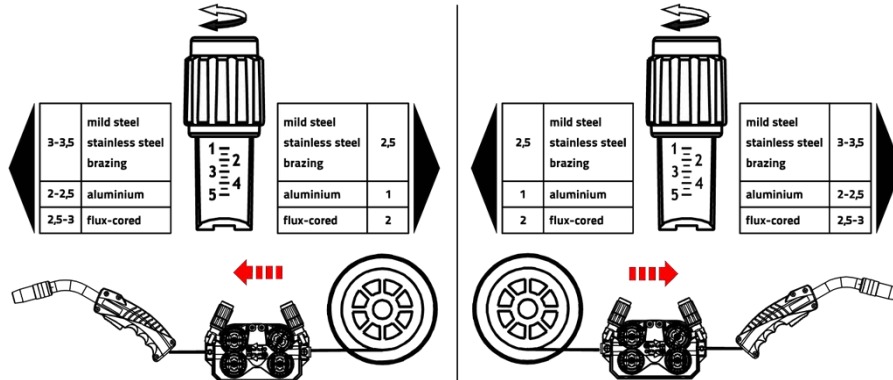

Figure 5-16

### Automatic inching stop

Touch the welding torch against the workpiece during inching. Inching of the welding wire will stop as soon it touches the workpiece.

#### 5.3.3.4 Spool brake setting

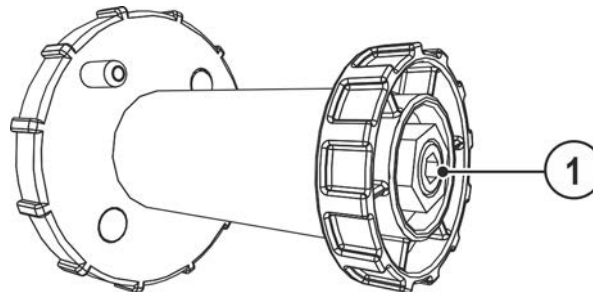

Figure 5-17

Item	Symbol	Description
1		<b>Allen screw</b> Securing the wire spool retainer and adjustment of the spool brake

- Tighten the Allen screw (8 mm) in the clockwise direction to increase the braking effect.

**Tighten the spool brake until the wire spool no longer turns when the wire feed motor stops but without it jamming during operation!**

#### 5.3.4 Standard MIG/MAG torch

The MIG welding torch trigger is essentially used to start and stop the welding process.

Operating elements	Functions
Torch trigger	<ul style="list-style-type: none"> <li>Start/stop welding</li> </ul>

#### 5.3.5 Welding task selection

For selection of the welding task and for general operation see the relevant Control operating instructions.

## 5.4 TIG welding

### 5.4.1 Welding torch connection

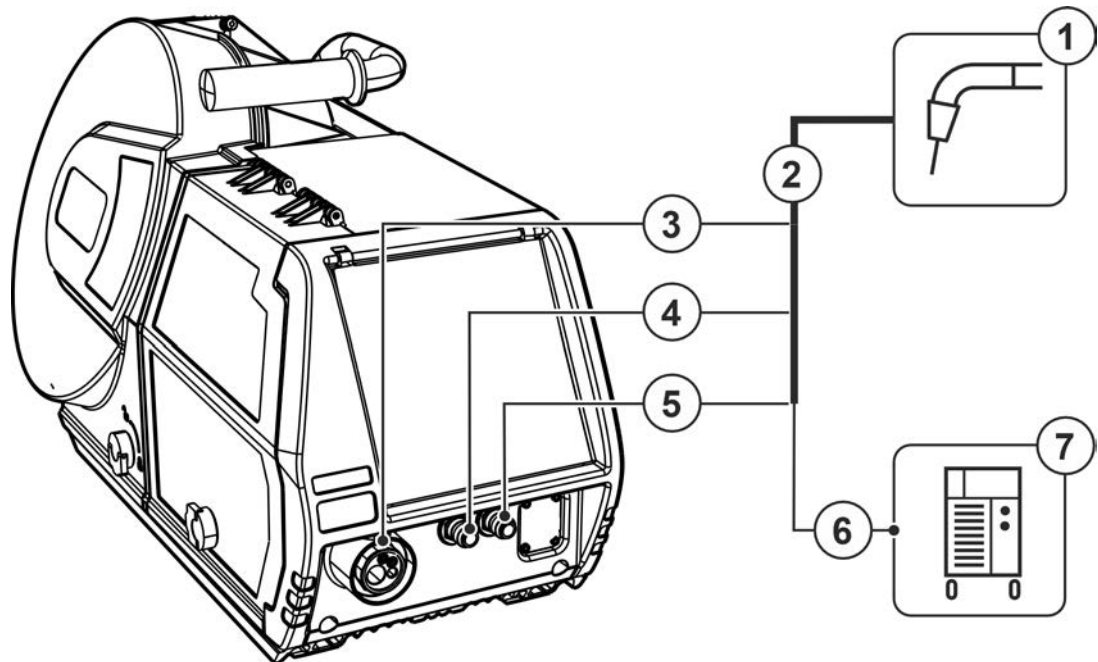

Figure 5-18

Item	Symbol	Description
1		<b>Welding torch</b>
2		<b>Welding torch hose package</b>
3		<b>Welding torch connection (Euro or Dinse torch connector)</b> Welding current, shielding gas and torch trigger integrated
4		<b>Quick connect coupling (blue)</b> coolant supply
5		<b>Quick connect coupling (red)</b> coolant return
6		<b>"-" welding current connection socket</b> • ----- TIG welding: Welding current connection for welding torch
7		<b>Power source</b>

- Insert the central plug for the welding torch into the central connector and screw together with crown nut.
- Insert the welding current plug of the combi welding torch into the (-) welding current connection socket and lock into place by turning to the right (only in case of a separate welding current connection).
- Lock connecting nipples of the cooling water tubes into the corresponding quick connect couplings: Return line red to quick connect coupling, red (coolant return) and supply line blue to quick connect coupling, blue (coolant supply).

### 5.4.2 Welding task selection

For selection of the welding task and for general operation see the relevant Control operating instructions.

## 6 Maintenance, care and disposal

### 6.1 General

**⚠ DANGER**

**Risk of injury due to electrical voltage after switching off!**  
**Working on an open machine can lead to fatal injuries!**  
**Capacitors are loaded with electrical voltage during operation. Voltage remains present for up to four minutes after the mains plug is removed.**

1. Switch off machine.
2. Remove the mains plug.
3. Wait for at least 4 minutes until the capacitors have discharged!

**⚠ WARNING**

**Improper maintenance, testing and repairs!**  
**Maintenance, testing and repair of the machine may only be carried out by skilled and qualified personnel (authorised service personnel). A competent person is someone who, based on training, knowledge and experience, can recognize the hazards and possible consequential damage that may occur when testing power sources and can take the necessary safety precautions.**

- Follow the maintenance instructions > see 6.3 chapter.
- If any of the test requirements below are not met, the unit must not be put back into operation until it has been repaired and tested again.

Repair and maintenance work may only be performed by qualified authorised personnel; otherwise the right to claim under warranty is void. In all service matters, always consult the dealer who supplied the machine. Return deliveries of defective equipment subject to warranty may only be made through your dealer. When replacing parts, use only original spare parts. When ordering spare parts, please quote the machine type, serial number and item number of the machine, as well as the type designation and item number of the spare part.

Under the specified ambient conditions and normal working conditions this machine is essentially maintenance-free and requires just a minimum of care.

Contamination of the machine may impair service life and duty cycle. The cleaning intervals depend on the ambient conditions and the resulting contamination of the machine. The minimum interval is every six months.

### 6.2 Explanation of icons

#### Personnel

	Welder / operator		Qualified person (authorised service personnel)
--	-------------------	--	---

#### Test

	Visual inspection		Functional test
--	-------------------	--	-----------------

#### Period, interval

	One-shift operation		Multi-shift operation
	Every 8 hours		Daily
	Weekly		Monthly
	Every 6 months		Annually

### 6.3 Maintenance schedule

Inspector	Type of inspection	8h	24h	Maintenance step	Repairer
				<p>! Only personnel designated as inspectors or repairers due to their training are allowed to carry out the relevant work step! Non-applicable inspection points are omitted.</p>	
				<ul style="list-style-type: none"> <li>Check and clean the welding torch. Deposits in the welding torch may cause short circuits, impair the welding result and lead to welding torch damage!</li> <li>Check wire drive, welding torches, and liner elements for application-related equipment and setting.</li> <li>Clean the wire feed rolls on a regular basis (depending on the degree of soiling). Replace worn wire feed rolls.</li> <li>Connections of the welding current leads (check for tight and locked seating).</li> <li>Is shielding gas cylinder with gas cylinder securing elements (chain/belt) secured?</li> <li>Strain relief: Are hose packages secured with strain relief?</li> </ul>	
				<ul style="list-style-type: none"> <li>Checking all supply lines and their connections (pipes, hoses, hose packages) for damage or leaks.</li> <li>Checking the welding system for damage to the housing.</li> <li>Transport elements (strap, lifting eyes, handle, wheels, parking brake) corresponding safety elements (if necessary fuse caps) are present and flawless?</li> </ul>	
				<ul style="list-style-type: none"> <li>Cleaning connections of coolant pipes (quick connect coupling, connections) from impurities and install protective caps when not in use.</li> <li>Gas test that the solenoid valve opens and closes properly.</li> <li>Checking operating, signalling and indicator lights, protective devices and actuators.</li> </ul>	
				<ul style="list-style-type: none"> <li>Check wire feed roll holder (wire feed rolls must be firmly seated on their holders and must not have any play)</li> <li>Cleaning dirt filter (if applicable)</li> </ul>	
				<ul style="list-style-type: none"> <li>Checking correct mounting of the wire spool.</li> </ul>	
				<ul style="list-style-type: none"> <li>Clean external surfaces with a damp cloth (do not use aggressive cleaning agents).</li> </ul>	
				<ul style="list-style-type: none"> <li>Cleaning the power source (inverter)</li> </ul>	
				<ul style="list-style-type: none"> <li>Cleaning heat exchanger (torch cooling)</li> </ul>	
				<ul style="list-style-type: none"> <li>Coolant change (torch cooling)</li> </ul>	
				<ul style="list-style-type: none"> <li>Periodic inspection and testing</li> </ul>	
				<ul style="list-style-type: none"> <li>The coolant must be checked using the appropriate frost protection tester TYP 1 (KF) or FSP (blueCool) for sufficient frost protection and replaced if necessary (accessories).</li> </ul>	

## 6.4 Disposing of equipment



### Proper disposal!

The machine contains valuable raw materials, which should be recycled, and electronic components, which must be disposed of.

- Do not dispose of in household waste!
- Observe the local regulations regarding disposal!

In addition to the national or international regulations mentioned below, it is mandatory to follow the respective national laws and regulations on disposal.

- According to European provisions (Directive 2012/19/EU on Waste of Electrical and Electronic Equipment), used electric and electronic equipment may no longer be placed in unsorted municipal waste. It must be collected separately. The symbol depicting a waste container on wheels indicates that the equipment must be collected separately.

This machine has to be disposed of, or recycled, in accordance with the waste separation systems in use.

According to German law (law governing the distribution, taking back and environmentally correct disposal of electrical and electronic equipment (ElektroG)), used machines are to be placed in a collection system separate from unsorted municipal waste. The public waste management utilities (communities) have created collection points at which used equipment from private households can be disposed of free of charge.

The deletion of personal data is the responsibility of the end user.

Lamps, batteries or accumulators must be removed and disposed of separately before disposing of the device. The type of battery or accumulator and its composition is marked on the top (type CR2032 or SR44). The following EWM products may contain batteries or accumulators:

- Welding helmets  
Batteries or accumulators are easy to remove from the LED cassette.
- Device controls  
Batteries or accumulators are located on the back of these in corresponding sockets on the circuit board and are easy to remove. The controls can be removed using standard tools.

Information on returning used equipment or collections can be obtained from the respective municipal administration office. Devices can also be returned to EWM sales partners across Europe.

Further information on the topic of the disposal of electrical and electronic equipment can be found on our website at: <https://www.ewm-group.com/de/nachhaltigkeit.html>.

## 7 Rectifying faults



All products are subject to rigorous production checks and final checks. If, despite this, something fails to work at any time, please check the product using the following flowchart. If none of the fault rectification procedures described leads to the correct functioning of the product, please inform your authorised dealer.

Legend	Symbol	Description
	↘	Fault/Cause
	✘	Remedy

### 7.1 Error messages (power source)

**The possible error numbers displayed depend on the machine series and version!**

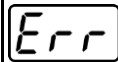
Depending on the options of the machine display, a fault is shown as follows:

Display type - machine control	Display
Graphic display	
two 7-segment displays	
one 7-segment display	

The possible cause of the fault is signalled by a corresponding fault number (see table). In the case of an error, the power unit shuts down.

- Document machine errors and inform service staff as necessary.
- If multiple errors occur, these are displayed in succession.

#### **Reset error (category legend)**

<sup>A</sup> The error message disappears when the error is eliminated.

<sup>B</sup> The error message can be reset by pressing a push-button ◀.

All other error messages can only be reset by switching the machine off and on again.

#### **Error 3: Tacho error**

Categories A, B

- ↘ Fault in the wire feeder.
  - ✘ Check the electrical connections (connectors, lines).
- ↘ Permanent overload of the wire drive.
  - ✘ Do not lay the liner in tight radii.
  - ✘ Check the wire in the liner for ease of movement.

#### **Error 4: Excess temperature**

Category A

- ↘ The power source is overheating.
  - ✘ Allow the switched-on machine to cool.
- ↘ Fan is blocked, dirty or faulty.
  - ✘ Check the fan and clean or replace it.
- ↘ Air inlet or outlet is blocked.
  - ✘ Check the air inlet and outlet.

#### **Error 5: Mains overvoltage**

Category A <sup>[1]</sup>

- ↘ Mains voltage is too high.
  - ✘ Check the mains voltages and compare them with the connection voltages of the power source.

## **Error 6: Mains undervoltage**

Category A <sup>[1]</sup>

- ↯ Mains voltage is too low.
  - ✘ Check the mains voltages and compare them with the connection voltages of the power source.

## **Error 7: Low coolant level**

Category B

- ↯ Low flow rate.
  - ✘ Fill with coolant.
  - ✘ Check coolant flow - remove kinks in the hose package.
  - ✘ Adjust the flow threshold <sup>[2]</sup>.
  - ✘ Clean the cooler.
- ↯ The pump does not turn.
  - ✘ Turn the pump shaft.
- ↯ Air in the coolant circuit.
  - ✘ Vent the coolant circuit.
- ↯ The hose package is not filled with coolant.
  - ✘ Switch the machine off and on > pump running > filling process.
- ↯ Operation with a gas-cooled welding torch.
  - ✘ Deactivate the torch cooling.
  - ✘ Connect the coolant feed and return with a hose bridge.

## **Error 8: Shielding gas error**

Categories A, B

- ↯ No gas.
  - ✘ Check the gas supply.
- ↯ The pre-pressure is too low.
  - ✘ Remove kinks in the hose package (nominal value: 4-6 bar pre-pressure).

## **Error 9: Secondary overvoltage**

- ↯ Overvoltage at the output: Inverter error.
  - ✘ Request service.

## **Error 10: Earth fault (PE error)**

- ↯ Connection between welding wire and machine casing.
  - ✘ Remove the electrical connection.
- ↯ Connection between welding circuit and machine casing.
  - ✘ Check the connection and routing of the earth wire / welding torch.

## **Error 11: Fast shut-down**

Categories A, B

- ↯ Remove the logical signal "Robot ready" during the process.
  - ✘ Eliminate errors in the higher-level control.



**Error 16: Pilot arc power source - collective error**

Category A

- ↘ The external emergency stop circuit has been interrupted.
  - ✘ Check the emergency stop circuit and eliminate the cause of the error.
- ↘ The emergency stop circuit of the power source has been activated (internally configurable).
  - ✘ Deactivate the emergency stop circuit.
- ↘ The power source is overheating.
  - ✘ Allow the switched-on machine to cool.
- ↘ Fan is blocked, dirty or faulty.
  - ✘ Check the fan and clean or replace it.
- ↘ Air inlet or outlet is blocked.
  - ✘ Check the air inlet and outlet.
- ↘ Short circuit on welding torch.
  - ✘ Check the welding torch.
  - ✘ Request service.

**Error 17: Cold wire error**

Category B

- ↘ Fault in the wire feeder.
  - ✘ Check the electrical connections (connectors, lines).
- ↘ Permanent overload of the wire drive.
  - ✘ Do not lay the liner in tight radii.
  - ✘ Check the liner for ease of movement.

**Error 18: Plasma gas error**

Category B

- ↘ No gas.
  - ✘ Check the gas supply.
- ↘ The pre-pressure is too low.
  - ✘ Remove kinks in the hose package (nominal value: 4-6 bar pre-pressure).

**Error 19: Shielding gas error**

Category B

- ↘ No gas.
  - ✘ Check the gas supply.
- ↘ The pre-pressure is too low.
  - ✘ Remove kinks in the hose package (nominal value: 4-6 bar pre-pressure).

## **Error 20: Low coolant level**

Category B

- ✓ Low flow rate.
  - ✘ Fill with coolant.
  - ✘ Check coolant flow - remove kinks in the hose package.
  - ✘ Adjust the flow threshold <sup>[2]</sup>.
  - ✘ Clean the cooler.
- ✓ The pump does not turn.
  - ✘ Turn the pump shaft.
- ✓ Air in the coolant circuit.
  - ✘ Vent the coolant circuit.
- ✓ The hose package is not filled with coolant.
  - ✘ Switch the machine off and on > pump running > filling process.
- ✓ Operation with a gas-cooled welding torch.
  - ✘ Deactivate the torch cooling.
  - ✘ Connect the coolant feed and return with a hose bridge.

## **Error 22: Excess coolant temperature**

Category B

- ✓ Coolant is overheating <sup>[2]</sup>.
  - ✘ Allow the switched-on machine to cool.
- ✓ Fan is blocked, dirty or faulty.
  - ✘ Check the fan and clean or replace it.
- ✓ Air inlet or outlet is blocked.
  - ✘ Check the air inlet and outlet.

## **Error 23: Excess temperature**

Category A

- ✓ External component (e.g. HF ignition units) overheated.
- ✓ The power source is overheating.
  - ✘ Allow the switched-on machine to cool.
- ✓ Fan is blocked, dirty or faulty.
  - ✘ Check the fan and clean or replace it.
- ✓ Air inlet or outlet is blocked.
  - ✘ Check the air inlet and outlet.

## **Error 24: Pilot arc ignition error**

Category B

- ✓ The pilot arc cannot ignite.
  - ✘ Check the welding torch equipment.

## **Error 25: Forming gas error**

Category B

- ✓ No gas.
  - ✘ Check the gas supply.
- ✓ The pre-pressure is too low.
  - ✘ Remove kinks in the hose package (nominal value: 4-6 bar pre-pressure).

**Error 26: Excess pilot arc module temperature**

Category A

- ✓ The power source is overheating.
  - ✘ Allow the switched-on machine to cool.
- ✓ Fan is blocked, dirty or faulty.
  - ✘ Check the fan and clean or replace it.
- ✓ Air inlet or outlet is blocked.
  - ✘ Check the air inlet and outlet.

**Error 32: Error I>0**

- ✓ The current detection is incorrect.
  - ✘ Request service.

**Error 33: Error UIST**

- ✓ Voltage recording is faulty.
  - ✘ Eliminate the short circuit in the welding circuit.
  - ✘ Remove the external sensor voltage.
  - ✘ Request service.

**Error 34: Electronics error**

- ✓ A/D channel error
  - ✘ Switch the machine off and on.
  - ✘ Request service.

**Error 35: Electronics error**

- ✓ Slope error
  - ✘ Switch the machine off and on.
  - ✘ Request service.

**Error 36:  fault**

- ✓  conditions violated.
  - ✘ Switch the machine off and on.
  - ✘ Request service.

**Error 37: Excess temperature / electronics error**

- ✓ The power source is overheating.
  - ✘ Allow the switched-on machine to cool.
- ✓ Fan is blocked, dirty or faulty.
  - ✘ Check the fan and clean or replace it.
- ✓ Air inlet or outlet is blocked.
  - ✘ Check the air inlet and outlet.

**Error 38: Error IIST**

- ✓ Short circuit in the welding circuit before welding.
  - ✘ Eliminate the short circuit in the welding circuit.
  - ✘ Request service.

**Error 39: Electronics error**

- ✓ Secondary overvoltage
  - ✘ Switch the machine off and on.
  - ✘ Request service.

## **Error 40: Electronics error**

- ✓ Error I>0
- ✘ Request service.

## **Error 47: Radio link (BT)**

- Category B
- ✓ Connection error between the welding machine and peripheral unit.
  - ✘ Note the documentation for the data interface with radio transmission.

## **Error 48: Ignition error**

- Category B
- ✓ No ignition at process start (automated machines).
  - ✘ Check the wire feeding
  - ✘ Check the load cable connections in the welding circuit.
  - ✘ Clean corroded surfaces on the workpiece before welding if necessary.

## **Error 49: Arc interruption**

- Category B
- ✓ An arc interruption occurred during welding with an automated system.
  - ✘ Check the wire feeding.
  - ✘ Adjust the welding speed.

## **Error 50: Program number**

- Category B
- ✓ Internal error.
  - ✘ Request service.

## **Error 51: Emergency stop**

- Category A
- ✓ The external emergency stop circuit has been interrupted.
  - ✘ Check the emergency stop circuit and eliminate the cause of the error.
  - ✓ The emergency stop circuit of the power source has been activated (internally configurable).
  - ✘ Deactivate the emergency stop circuit.

## **Error 52: No wire feeder**

- ✓ After switching on the automated system, no wire feeder (DV) was detected.
- ✘ Check or connect the control cables of the wire feeders.
- ✘ Check the identification number of the automated wire feeder (for 1DV: number 1, for 2DV: each a wire feeder with number 1 and a wire feeder with number 2).

## **Error 53: No wire feeder 2**

- Category B
- ✓ Wire feeder 2 was not detected.
  - ✘ Check the control cable connections.

## **Error 54: VRD fault**

- ✓ Error in the voltage reduction device.
- ✘ If necessary, disconnect the external machine from the welding circuit.
- ✘ Request service.

## **Error 55: Excess wire feeder current**

- Category B
- ✓ Excess current detected in the wire feed mechanism.
  - ✘ Do not lay the liner in tight radii.
  - ✘ Check the liner for ease of movement.

**Error 56: Mains phase failure**

- ✓ One phase of the mains voltage has failed.
- ✘ Check the mains connection, mains plug and mains fuses.

**Error 57: Slave tacho error**

Category B

- ✓ Fault in the wire feeder (slave drive).
- ✘ Check the connections (connectors, lines).
- ✓ Permanent overload of the wire drive (slave drive).
- ✘ Do not lay the liner in tight radii.
- ✘ Check the liner for ease of movement.

**Error 58: Short circuit**

Category B

- ✓ Short circuit in the welding circuit.
- ✘ Eliminate the short circuit in the welding circuit.
- ✘ Place the welding torch on an insulated surface.

**Error 59: Incompatible machine**

- ✓ A machine connected to the system is not compatible.
- ✘ Disconnect the incompatible machine from the system.

**Error 60: Incompatible software**

- ✓ The software of a machine is not compatible.
- ✘ Disconnect the incompatible machine from the system
- ✘ Request service.

**Error 61: Welding monitoring**

- ✓ The actual value of a welding parameter is outside the specified tolerance range.
- ✘ Maintain the tolerance ranges.
- ✘ Adjust the welding parameters.

**Error 62: System component**

- ✓ The system component was not found.
- ✘ Request service.

**Error 63: Mains voltage error**

- ✓ Operating and mains voltage are incompatible.
- ✘ Check or adjust the operating and mains voltage.

<sup>[1]</sup> only Picotig 220 pulse

<sup>[2]</sup> See technical data for values and other switching thresholds > see 8 chapter.

## 7.2 Warnings

Depending on the display options of the machine display, a warning message is displayed as follows:

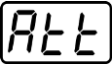
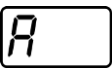
Display type - machine control	Display
Graphic display	
two 7-segment displays	
one 7-segment display	

The cause of the warning is indicated by a corresponding warning number (see table).

- In case of multiple warnings, these are displayed in sequence.
- Document machine warning and inform service personnel, if required.

Warning	Potential cause / remedy
1 Excess temperature	A shutdown is imminent due to excess temperature.
2 Half-wave failures	Check process parameters.
3 Welding torch cooling warning	Check the coolant level and top up if necessary.
4 Shielding gas	Check the shielding gas supply.
5 Coolant flow	Check min. flow rate. <sup>[2]</sup>
6 Wire reserve	Only a small amount of wire is left on the spool.
7 CAN bus failure	The wire feeder is not connected; the automatic circuit-breaker of the wire feed motor (reset the tripped automatic circuit breaker by actuating).
8 Welding circuit	The inductance of the welding circuit is too high for the selected welding task.
9 WF configuration	Check WF configuration.
10 Partial inverter	One of several partial inverters is not supplying welding current.
11 Excess temperature of the coolant <sup>[1]</sup>	Check temperature and switching thresholds. <sup>[2]</sup>
12 Welding monitoring	The actual value of a welding parameter is outside the specified tolerance range.
13 Contact error	The resistance in the welding circuit is too high. Check the earth connection.
14 Alignment error	Switch the machine off and on. If the error persists, notify Service.
15 Mains fuse	The power limit of the mains fuse is reached and the welding power is reduced. Check the fuse setting.
16 Shielding gas warning	Check the gas supply.
17 Plasma gas warning	Check the gas supply.
18 Forming gas warning	Check the gas supply.
19 Gas warning 4	reserved
20 Coolant temperature warning	Check the coolant level and top up if necessary.
21 Excess temperature 2	reserved
22 Excess temperature 3	reserved
23 Excess temperature 4	reserved

Warning	Potential cause / remedy
24 Coolant flow warning	Check the coolant supply. Check the coolant level and top up if necessary. Check flow and switching thresholds. <sup>[2]</sup>
25 Flow 2	reserved
26 Flow 3	reserved
27 Flow 4	reserved
28 Wire stock warning	Check the wire feeding.
29 Low wire 2	reserved
30 Low wire 3	reserved
31 Low wire 4	reserved
32 Tacho error	Fault of the wire feeder - permanent overload of the wire drive.
33 Wire feed motor excess current	Excess current detected on wire feed motor.
34 JOB unknown	JOB selection was not carried out because the JOB number is unknown.
35 Wire feed motor slave excess current	Excess current detected on wire feed motor slave (push/push system or intermediate drive).
36 Slave tacho error	Fault of the wire feeder - permanent overload of the wire drive (push/push system or intermediate drive).
37 FAST bus failure	The wire feeder is not connected (reset by actuating the automatic circuit breaker of the wire feed motor).
38 Incomplete component information	Check the Xnet component management.
39 Halfwave failure	Check supply voltage.
40 Weak power grid	Check supply voltage.
41 Cooling unit not recognised	A liquid-cooled welding torch was connected but no cooling unit has been detected. <ul style="list-style-type: none"> <li>• Check the connection of the cooling unit</li> <li>• Use a gas-cooled welding torch</li> </ul>
47 Battery (remote control, type BT)	Battery level is low (replace battery)

<sup>[1]</sup> only for the XQ machine series

<sup>[2]</sup> See technical data for values and other switching thresholds > see 8 chapter.

## 7.3 Checklist for rectifying faults

**The correct machine equipment for the material and process gas in use is a fundamental requirement for perfect operation!**

Legend	Symbol	Description
	↗	Fault/Cause
	✘	Remedy

## **Functional errors**

- ✓ Mains fuse triggers - unsuitable mains fuse
  - ✗ Set up recommended mains fuse > see 8 chapter.
- ✓ Machine does not start up after switching on (device fan and possibly coolant pump have no function).
  - ✗ Connect the control cable of the wire feeder.
- ✓ All machine control signal lights are illuminated after switching on
- ✓ No machine control signal light is illuminated after switching on
- ✓ No welding power
  - ✗ Phase failure > check mains connection (fuses)
- ✓ Machine restarts continuously
- ✓ Wire feeder without function
- ✓ System does not start up
  - ✗ Make control lead connections and check that they are fitted correctly.
- ✓ Loose welding current connections
  - ✗ Tighten power connections on the torch and/or on the workpiece
  - ✗ Properly fasten the contact tip and contact tip holder.

## **Collective interference signal light illuminates**

- ✓ Excess temperature, welding machine
  - ✗ Allow the machine to cool down whilst still switched on
- ✓ Welding current monitoring device triggered (stray welding currents flowing across the protective earth). The error must be reset by switching the machine off and on again.
  - ✗ Welding wire is touching electrically conductive casing parts (check wire guide, has the welding wire sprung off the wire spool?).
  - ✗ Check for a correct mounting of the welding lead. Fit the feeder clamp of the welding lead as close as possible to the arc.

## **Excess temperature signal light illuminates**

- ✓ Excess temperature, welding machine
  - ✗ Allow the machine to cool down whilst still switched on

## **Coolant error/no coolant flowing**

- ✓ Insufficient coolant flow
  - ✗ Check coolant level and refill if necessary
- ✓ Air in the coolant circuit
  - ✗ Vent coolant circuit > see 7.4 chapter



## Wire feed problems

- ✓ Wire feed roll holder is worn (wire feed rolls must be firmly seated on their holders and must not have any play)
  - ✗ Replace wire feed roll holder (092-002960-E0000) > see 10.1.4 chapter
- ✓ Contact tip blocked
  - ✗ Clean and, if necessary, replace.
- ✓ Setting the spool brake > see 5.3.3.4 chapter
  - ✗ Check settings and correct if necessary
- ✓ Setting pressure units > see 5.3.3.3 chapter
  - ✗ Check settings and correct if necessary
- ✓ Worn wire rolls
  - ✗ Check and replace if necessary
- ✓ Wire feed motor without supply voltage (automatic cutout triggered by overloading)
  - ✗ Reset triggered fuse (rear of the power source) by pressing the key button
- ✓ Kinked hose packages
  - ✗ Extend and lay out the torch hose package
- ✓ Wire guide core or spiral is dirty or worn
  - ✗ Clean core or spiral; replace kinked or worn cores

## 7.4 Vent coolant circuit

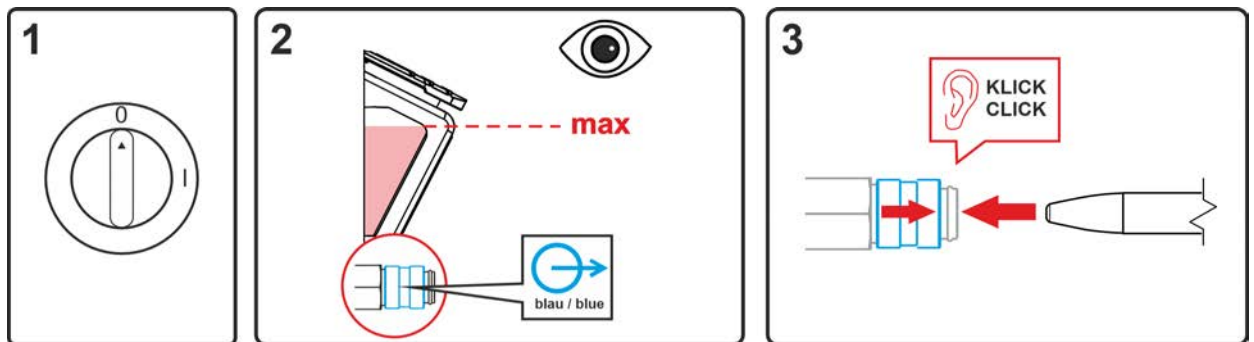

Figure 7-1

- Switch off the machine and fill the coolant tank to the maximum level.
- Unlock the quick-connect coupling with a suitable tool (connection open).

**To vent the cooling system always use the blue coolant connection, which is located as deep as possible inside the system (close to the coolant tank)!**

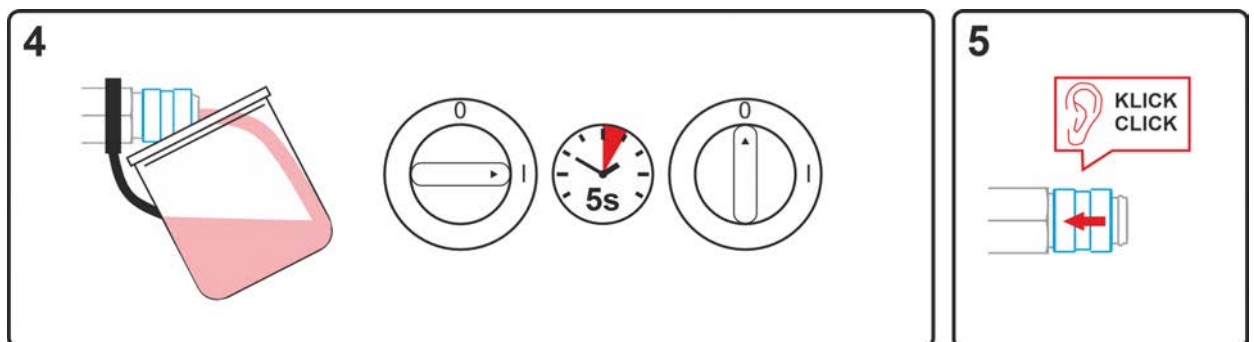

Figure 7-2

- Position a suitable collection container for collecting the escaping coolant at the quick-connect coupling and switch on the machine for approx. 5s.
- Lock the quick-connect coupling by pushing back the locking ring.

## 8 Technical data

Performance specifications and guarantee only in connection with original spare and replacement parts!

### 8.1 Drive 4X S

<b>Supply voltage (from the welding machine)</b>	42 VAC
<b>Duty cycle DC at 40° C <sup>[1]</sup></b>	
40 %	600 A
100 %	470 A
<b>Power consumption P<sub>i</sub></b>	8 W
<b>Wire feed speed</b>	0,5 m/min to 25 m/min
<b>Factory-installed roll equipment</b>	1,0-1,2 mm (for steel wire)
<b>Drive</b>	4 rollers (37 mm)
<b>Wire spool diameter</b>	Standardised wire spools up to 300 mm
<b>Welding torch connection</b>	Euro torch connector
<b>Contamination level / protection classification</b>	3 / IP 23
<b>Overvoltage category</b>	III
<b>Ambient temperature <sup>[2]</sup></b>	-25 °C to +40 °C
<b>EMC class</b>	A
<b>Test mark</b>	CE / ENEC / UK
<b>Standards used</b>	See declaration of conformity (appliance documents)
<b>Dimensions (l x b x h)</b>	660 x 280 x 380 mm 26.0 x 11.0 x 15.0 inch
<b>Weight</b>	14,2 kg 31.3 lb

<sup>[1]</sup> Load cycle: 10 min. (60 % DC  $\pm$  6 min. welding, 4 min. pause)

<sup>[2]</sup> Ambient temperature dependent on coolant! Observe coolant temperature range!

## 9 Accessories

Performance-dependent accessories like torches, workpiece leads, electrode holders or intermediate hose packages are available from your authorised dealer.

### 9.1 Welding torch cooling system

Type	Designation	Item no.
HOSE BRIDGE UNI	Tube bridge	092-007843-00000
LFMG HANNA DIST 3	Conductivity meter	094-026184-00000

#### 9.1.1 Coolant - type blueCool

Type	Designation	Item no.
blueCool -10 5 l	Coolant up to -10 °C (14 °F), 5 l	094-024141-00005
blueCool -10 25 l	Coolant up to -10 °C (14 °F), 25 l	094-024141-00025
blueCool -30 5 l	Coolant up to -30 °C (22 °F), 5 l	094-024142-00005
blueCool -30 25 l	Coolant up to -30 °C (22 °F), 25 l	094-024142-00025
FSP blueCool	Frost protection tester	094-026477-00000

### 9.2 Option for retrofitting

Type	Designation	Item no.
ON WAK D01	Wheel assembly kit	092-002844-00000
ON RFAK D01	Rubber feet	092-002845-00000
ON GK D01	Metal runners	092-003030-00000
ON SET WF 2,0-3,2mm eFeed	Wire feed set for rolls with diameters greater than 1.6 mm	092-019404-00000
ON CC D01	Transparent cover cap for protection of device control	092-002834-00000
ON TS D01/D02	Torch holder	092-002836-00000
ON TS F2/F3 D.01	Holder for fume extraction torch	092-004323-00000
ON FLOWMETER	Option analogue gas flow control with gas flow meter	092-003374-00000
ON CONNECTOR WIRE CONDUIT D.01/D.02	Connection for wire feeder for wire feeding from a drum	092-002842-00000
ON PDM D.01 LP-XQ / Basic-XQ	Transparent protective screen for the wire feeder controls	092-003788-00000
ON TCC D01	Set comprised of crane suspension and protective plate, for use of the wire feeder in lateral position	092-002835-00000
ON CMF D01	Crane suspension	092-002833-00000
ON PS EXT D01	Retrofit set: Extension turning mandrel, for holding a wire feeder with wheel kit ON WAK D01	092-002871-00000
ON PDM D.01 HP-XQ / Steel puls S / Steel Synergic S / Basic S	Transparent protective screen for the wire feed controls	092-003478-00000
ON PDM D.01 Expert-XQ 2.0 / Expert 2.0	Transparent protective screen for the wire feed controls	092-003480-00000
ON HASE XQ	Support arm for the torch hose package	092-004314-00000

### 9.3 General accessories

Type	Designation	Item no.
ADAP DZA/EZA	Adapter for welding torches with Dinse connector to Euro torch connector on the machine	094-016765-00000
DSP	Sharpener for liner	094-010427-00000
Cutter	Hose cutter	094-016585-00000

## 10 Replaceable parts

Performance specifications and guarantee only in connection with original spare and replacement parts!

### 10.1 Wire feed rollers

#### 10.1.1 Wire feed rollers for steel wire

Type	Designation	Item no.
FE 4R 0.6 MM/0.023 INCH LIGHT PINK	Drive roll set, 37 mm, 4 rolls, V-groove for steel, stainless steel and brazing	092-002770-00006
FE 4R 0.8-1.0MM / 0.03-0.04 INCH BLUE/WHITE	Drive roll set, 37 mm, 4 rolls, V-groove for steel, stainless steel and brazing	092-002770-00009
FE 4R 1.0-1.2MM / 0.04-0.045 INCH BLUE/RED	Drive roll set, 37 mm, 4 rolls, V-groove for steel, stainless steel and brazing	092-002770-00011
FE 4R 1.4 MM/0.052 INCH GREEN	Drive roll set, 37 mm, 4 rolls, V-groove for steel, stainless steel and brazing	092-002770-00014
FE 4R 1.6 MM/0.06 INCH BLACK	Drive roll set, 37 mm, 4 rolls, V-groove for steel, stainless steel and brazing	092-002770-00016
FE 4R 2.0 MM/0.08 INCH GREY	Drive roll set, 37 mm, 4 rolls, V-groove for steel, stainless steel and brazing	092-002770-00020
FE 4R 2.4 MM/0.095 INCH BROWN	Drive roll set, 37 mm, 4 rolls, V-groove for steel, stainless steel and brazing	092-002770-00024
FE 4R 2.8 MM/0.11 INCH LIGHT GREEN	Drive roll set, 37 mm, 4 rolls, V-groove for steel, stainless steel and brazing	092-002770-00028
FE 4R 3.2 MM/0.12 INCH VIOLET	Drive roll set, 37 mm, 4 rolls, V-groove for steel, stainless steel and brazing	092-002770-00032

#### 10.1.2 Wire feed rollers for aluminium wire

Type	Designation	Item no.
AL 4R 0.8 MM/0.03 INCH WHITE/YELLOW	Drive roll set, 37 mm, for aluminium	092-002771-00008
AL 4R 1.0 MM/0.04 INCH BLUE/YELLOW	Drive roll set, 37 mm, for aluminium	092-002771-00010
AL 4R 1.2 MM/0.045 INCH RED/YELLOW	Drive roll set, 37 mm, for aluminium	092-002771-00012
AL 4R 1.6 MM/0.06 INCH BLACK/YELLOW	Drive roll set, 37 mm, for aluminium	092-002771-00016
AL 4R 2.0 MM/0.08 INCH GREY/YELLOW	Drive roll set, 37 mm, for aluminium	092-002771-00020
AL 4R 2.4 MM/0.095 INCH BROWN/YELLOW	Drive roll set, 37 mm, for aluminium	092-002771-00024
AL 4R 2.8 MM/0.110 INCH LIGHT GREEN/YELLOW	Drive roll set, 37 mm, for aluminium	092-002771-00028
AL 4R 3.2 MM/0.125 INCH VIOLET/YELLOW	Drive roll set, 37 mm, for aluminium	092-002771-00032

**10.1.3 Wire feed rollers for cored wire**

Type	Designation	Item no.
FUEL 4R 0.8 MM/0.03 INCH WHITE/ORANGE	Drive roll set, 37 mm, 4 rolls, V-groove/knurled for flux cored wire	092-002848-00008
FUEL 4R 1.0 MM/0.04 INCH BLUE/ORANGE	Drive roll set, 37 mm, 4 rolls, V-groove/knurled for flux cored wire	092-002848-00010
FUEL 4R 1.2 MM/0.045 INCH RED/ORANGE	Drive roll set, 37 mm, 4 rolls, V-groove/knurled for flux cored wire	092-002848-00012
FUEL 4R 1.4 MM/0.052 INCH GREEN/ORANGE	Drive roll set, 37 mm, 4 rolls, V-groove/knurled for flux cored wire	092-002848-00014
FUEL 4R 1.6 MM/0.06 INCH BLACK/ORANGE	Drive roll set, 37 mm, 4 rolls, V-groove/knurled for flux cored wire	092-002848-00016
FUEL 4R 2.0 MM/0.08 INCH GREY/ORANGE	Drive roll set, 37 mm, 4 rolls, V-groove/knurled for flux cored wire	092-002848-00020
FUEL 4R 2.4 MM/0.095 INCH BROWN/ORANGE	Drive roll set, 37 mm, 4 rolls, V-groove/knurled for flux cored wire	092-002848-00024



**10.1.4 Wire guide**

Type	Designation	Item no.
DV X	Wire feed roll mount set	092-002960-E0000
SET WF 1,6mm eFeed	Wire feed set for rolls up to 1.6 mm in diameter	092-002774-00000
ON SET WF 2,0-3,2mm eFeed	Wire feed set for rolls with diameters greater than 1.6 mm	092-019404-00000
SET IG 4x4 1.6mm BL	Inlet guide set	092-002780-00000
GUIDE TUBE L105	Guide tube	094-006051-00000
GuideTube L=102 mm, Ø 4,4 x 5 mm	Guide tube	094-020064-00000
CAPTUB L=107 mm; Ø ≤ 1,6 mm	Capillary tube	094-006634-00000
CAPTUB L=105 mm; Ø ≤ 2,4 mm	Capillary tube	094-021470-00000

## 11 Appendix

### 11.1 Average wire electrode usage

5 m/min – 197 ipm

	mm				inch			
	1.0	1.2	1.6		.040	.045	.060	
Steel	1.8	2.7	4.7	kg/h	3.9	5.9	10.3	lb/h
Stainless steel	1.9	2.8	4.8		4.1	6.1	10.5	
Aluminium	0.6	0.9	1.6		1.3	1.9	3.5	

10 m/min – 394 ipm

Steel	3.7	5.3	9.5	kg/h	8.1	11.6	20.9	lb/h
Stainless steel	3.8	5.4	9.6		8.3	11.9	21.1	
Aluminium	1.3	1.8	3.2		2.8	3.9	7.0	

### 11.2 Average shielding gas usage

#### 11.2.1 MIG/MAG welding

	mm	1.0	1.2	1.6	2.0
	inch	.040	.045	.060	.080
l/min		10	12	16	20
gal/min		2.64	3.17	4.22	5.28

#### 11.2.2 TIG welding

	Gas nozzle number	4	5	6	7	8	10
	∅ mm	6.5	8.0	9.5	11	12.5	16
	∅ inch	0.26	0.31	0.37	0.43	0.5	0.63
l/min		6	8	10	12		15
gal/min		1.58	2.11	2.64	3.17		3.96

### 11.3 Searching for a dealer

Sales & service partners  
[www.ewm-group.com/en/specialist-dealers](http://www.ewm-group.com/en/specialist-dealers)



**"More than 400 EWM sales partners worldwide"**